



KeyVoice[®]
Voice Processing

DEBUT AND LITE SYSTEM INSTALLATION AND SUPERVISOR GUIDE



KEY VOICE[®]

Everything Your Business Calls For

LIMITED WARRANTY

The initial hardware and software of all Key Voice Technologies, Inc. (“Key Voice”) products accompanying this installation manual shall be referred to collectively herein as the “Product”. Non-Key Voice products are warranted solely by the manufacturer in accordance with the manufacturer’s warranty, and are sold by Key Voice “as is”. Key Voice warrants, to its purchaser, its authorized dealers and the end users of the Product, that, under normal operating conditions, (a) the Product hardware (except for fuses, lamps and other consumables) and the medium on which the Product software is contained will be free from defects in material and workmanship, and (b) the Product software will perform substantially in accordance with the specifications set out in the user guide accompanying the Product which is prepared by Key Voice, in each case for a period of one year, measured from the manufacturing date stamped on the Product hardware or software, as the case may be, provided however, development products, i.e., products which have not yet been approved by Key Voice for production, are sold pursuant to Key Voice’s field trial agreement and are warranted as set out therein. Key Voice’s sole obligation under this warranty or under any other legal obligation with respect to the Product is to repair or replace, at its option, the Product at its Sarasota, Florida, headquarters, free of charge, if the Product is deemed defective by Key Voice during the warranty period, with refurbished or new equipment or parts, at Key Voice’s option, when the Product is returned to Key Voice, freight or postage prepaid, during the warranty period, provided however, if Key Voice is not able, using reasonable efforts, to cure or correct a defect, Key Voice’s sole obligation shall then be to refund (or cause to be refunded) an equitable portion of the price Key Voice was paid for the Product. This warranty does not apply if, in the sole judgment of Key Voice, the Product, or any part(s) or component(s) thereof, have been improperly installed or installed or used in combination or in assembly with hardware or software not supplied by Key Voice and which are not compatible with the Product or which are of inferior quality, design or performance, or the Product, or any part(s) or component(s) thereof, have been improperly handled, misused, abused, altered, tampered with, accidentally damaged, or damaged or malfunction or fail to function due to neglect, negligence, contamination (by liquid or otherwise) or as a result of any other causes beyond Key Voice’s reasonable control, including extraordinary wear and tear and acts of God such as fire, flood, water, or lightning or other incidence of excessive or insufficient voltage or failure to follow instructions. Repair, wiring, or alteration of the Product other than as specifically authorized by Key Voice or its authorized repair agent is prohibited and will void this warranty. This warranty does not cover costs associated with installation, removal, or reinstallation of the Product. Key Voice does not warrant that the Product is compatible with all telephone or switching systems or that the Product is invulnerable or immune from unauthorized or fraudulent use, or unaccounted for access to the Product. **THIS WARRANTY IS EXCLUSIVE, BEING IN LIEU OF ALL OTHER WARRANTIES EXPRESS OR IMPLIED, INCLUDING, BUT NOT LIMITED TO, ANY IMPLIED WARRANTY OF MERCHANTABILITY OR FITNESS FOR A PARTICULAR PURPOSE.**

LIMITATION OF LIABILITY

WITHOUT EXPANDING UPON THE FOREGOING WARRANTY, THE MAXIMUM LIABILITY OF KEY VOICE UNDER ANY WARRANTY, STATUTORY, EXPRESS OR IMPLIED, IS LIMITED TO THE PURCHASE PRICE OF THE PRODUCT. KEY VOICE SHALL HAVE NO RESPONSIBILITY FOR DAMAGE TO PROPERTY OR ANY OTHER LOSS OR INJURY, INCLUDING CONSEQUENTIAL, INCIDENTAL, OR INDIRECT DAMAGES, SUCH AS LOSS OF PROFITS OR LOSS OF BUSINESS INFORMATION, DAMAGES DUE TO BUSINESS INTERRUPTION OR ANY OTHER PECUNIARY LOSS, EVEN IF KEY VOICE HAS BEEN ADVISED OF THE POSSIBILITY OF SUCH DAMAGES, OR PUNITIVE DAMAGES, RESULTING FROM THE PURCHASE, POSSESSION, INSTALLATION, OPERATION, REPAIR, USE OF PURCHASE, POSSESSION, INSTALLATION, OPERATION, REPAIR, USE OF OR INABILITY TO USE, THE PRODUCT, OR THE UNAUTHORIZED OR THE FRAUDULENT USE OF, OR UNACCOUNTED FOR ACCESS TO, THE PRODUCT, ALL SUCH CLAIMS BEING HEREBY EXPRESSLY WAIVED. THE PURCHASER'S EXCLUSIVE WARRANTY AND REMEDY SHALL BE ONLY AS STATED HEREIN.

This warranty gives you specific legal rights and you may also have other rights which may vary from state to state. Some states do not allow limitation on how long an implied warranty lasts or the exclusion or limitation of incidental or consequential damages, so the above limitations may not apply to you. If the Magnuson Moss Act should be held to apply to the sale of the Product by a court of competent jurisdiction, the implied warranty of fitness for a particular purpose shall extend for one year from the date of manufacture. No Key Voice dealer nor any other person or entity other than Key Voice may extend or modify this warranty, and no such modification or extension shall be effective unless it is in writing.

REVISION HISTORY

Version	Changes	Owner	Date
4/00	Updated to reflect functionality enhancements incorporated into the DOS-based VP system release 8.3. Sections affected: 2	Serena Smith	04-10-2000
4/00	Updated section 2.5.5.1 to reflect additional integrations in release 8.3.	Serena Smith	04-17-2000
5/00	Updated section 1.2 to indicate additional box types available. Updated section 2.3.2 to indicate phone system connection information for the Debut unit. Updated section 2.5.2 to indicate additional troubleshooting information. Updated 2.7.1 to indicate additional phone systems available with Debut integrations.	Kathleen Dickason	05-31-2000
8/00	Updated section 2.5.2 to indicate resolution requirements for the Serial Administrator interface. Updated 2.5.5.1 and 2.7.1.1 to indicate that SMDI Centrex integration is available only with Lite systems.	Serena Smith	8-21-2000
9/00	Corrected special characters table in section 2.7.2 and descriptions for teleparameter codes 2121 and 2124.	Serena Smith	9-05-2000
12/00	Adjusted listing of supported integrations and associated teleparameter values.	Kathy Dickason	12-20-2000

Table of Contents

1. System Overview	1
1.1 What Does the Lite System Do?	1
1.1.1 What is an Automated Attendant?	1
1.1.2 What is Voice Mail?	2
1.2 Understanding the Lite System Product Design.....	3
2. System Setup Instructions.....	5
2.1 Available System Setup Techniques.....	5
2.2 Preparing for System Setup	7
2.3 Connecting the Lite System Unit to the Telephone System.....	8
2.3.1 Connecting Directly to the Central Office (C.O.)	8
2.3.2 Connecting the Lite System to a PBX or Key System.....	9
Typical Setup	12
2.4 Collecting Necessary Customer Information.....	12
2.5 Setting Up the System by Attaching a Laptop.....	21
2.5.1 Installing Serial Administration Software on the Laptop.....	21
2.5.2 Connecting the Laptop to the Lite System Unit	22
2.5.3 Completing the First Time Setup Procedure.....	26
2.5.4 Running the First Time Setup Utility	26
2.5.5 Specifying System Information	26
2.5.5.1 Integration Defaults Set by the Integration Program.....	27
2.5.5.2 Using Technical Bulletin Information.....	30
2.5.5.3 Accessing System Information Screens	31
2.5.5.4 Setting Up the General Information Screen	31
2.5.5.5 Setting Up the Line Information Screen	31
2.5.5.6 Setting Up the Business Hours Screen.....	32
2.5.5.7 Setting Up the Call Transfer Screen.....	32
2.5.5.8 Setting Up the Class of Service Screen.....	33
2.5.6 Specifying Box Information.....	40
2.5.6.1 What Is a Box?.....	40
2.5.6.2 Understanding Routing Box 800, 801, and 821	40

2.5.6.3 Accessing Box Information Screens.....	41
2.5.6.4 Reviewing Routing Box 800, 801, and 821 and Setting Up Single-Digit Call Routing.....	43
2.5.6.5 Setting Up Prototype Mailbox 9994.....	44
2.5.6.6 Creating Subscriber Mailboxes.....	47
2.5.6.7 Customizing Subscriber Mailboxes.....	48
2.5.6.8 Customizing the System Supervisor Mailbox.....	57
2.5.6.9 Recording Routing Box Greetings.....	57
2.6 Default Database Structure Overview.....	60
2.7 Setting Up the System Using the Teleparameter Feature.....	62
2.7.1 Using the Teleparameter Feature to Set up a New System.....	63
2.7.1.1 Running the First Time Setup Utility.....	63
2.7.1.2 Adjusting System Information.....	68
2.7.1.3 Adjusting Routing Box Information.....	69
2.7.1.4 Creating and Adjusting Mailbox Box Information.....	70
2.7.1.5 Creating Other Box Types and Adjusting Information.....	71
2.7.2 Teleparameter Value Tables.....	71
2.7.3 Using the Teleparameter Feature to Adjust the System Setup.....	103
2.8 Upgrading 2 Port Systems to 4 Ports.....	104
3. System Supervisor Instructions.....	105
3.1 Working with Mailboxes.....	105
3.1.1 Adding, Deleting, or Modifying a Mailbox.....	105
3.2 Working with Routing Boxes.....	110
3.2.1 Understanding the Routing Box Setup.....	110
3.2.2 Recording Routing Box Greetings or Changing Currently Active Greetings.....	113
3.2.3 Changing the Single-Digit Call Routing.....	115
3.3 General System Maintenance.....	117
3.3.1 Enabling or Disabling a Port.....	117
3.3.2 Recording a Broadcast Message for All Mailboxes.....	118
3.3.3 Transferring a Caller to a Mailbox's Voice Mail.....	119
3.3.4 Troubleshooting System Problems.....	120

1. System Overview

This document discusses features and functionality provided in Small Office Lite[®] systems (including the Small Office Lite–Star system) and Debut[®] systems. Note that these systems include the same feature set, and the system setup and maintenance procedures are nearly identical between systems. Therefore, for documentation ease, these systems are collectively referred to as the *Lite* system in this guide.

1.1 What Does the Lite System Do?

In its simplest form, the Lite system acts like a telephone receptionist. The system answers incoming calls and transfers them to the appropriate extension. If the called extension is not available (busy or no answer), the system offers to take a message or try an alternative extension.

Lite system functionality includes:

- Automated attendant features
- Voice mail features

These two functions work together to provide smooth call coverage for your application.

1.1.1 What is an Automated Attendant?

The Lite system automated attendant features perform the tasks of a live attendant. The following table illustrates how.

Live Attendant	Lite System Automated Attendant
Answers an incoming call by lifting telephone.	Answers an incoming call by going "off-hook."
Greets the caller with "Welcome to [XYZ Company]."	Greets the caller by playing a pre-recorded greeting, "Welcome to [XYZ Company]."

Live Attendant	Lite System Automated Attendant
Asks to whom the caller wishes to speak.	Plays a pre-recorded greeting that prompts the caller to either dial the extension of the party they are trying to reach or choose from a list of voiced options to route their call to a specific department or group.
Listens to the caller's response.	Listens to the digits dialed by the caller.
Says "Please hold."	Plays a pre-record phrase <i>"Please hold..."</i>
Calls the required extension, by hook-flashing and dialing the extension number.	Calls the required extension, by hook-flashing and dialing the extension number.
Listens for busy tone, ring tone, answer, etc.	Listens for busy tone, ring tone, answer, etc.
If the extension is busy, offers to let the caller hold. If the extension does not answer, offers to take a message or try another extension.	If the extension is busy, plays a pre-recorded prompt, offering the option to hold. If the extension does not answer, plays a pre-recorded prompt offering to take a message or try another extension.

1.1.2 What is Voice Mail?

The term "voice mail" refers to systems that can record a voice message and treat it like a mail message. In a typical office environment, the live attendant takes a message from a caller and writes it down on a piece of paper. The attendant then places the slip in the recipient's in-box or "mailbox." The box owner then retrieves and reads the message placed in the box.

In contrast, the Lite system records a message from a caller and places it in a voice mailbox. The mailbox owner can later retrieve the message by calling into the Lite system and listening to the recording. The table below compares how the Lite system processes voice messages compared to a live attendant.

Live Attendant	Lite System Voice Mail
Attendant listens as the caller dictates his/her message, writing it down on a piece of paper.	The Lite system records the message as the caller speaks.
Attendant places the message slip in a mailbox belonging to the recipient.	The Lite system stores the voice message electronically in the recipient's voice mailbox.

Live Attendant	Lite System Voice Mail
Attendant dials code to turn on message waiting lamp on recipient's telephone.	The Lite system dials code to turn on the message waiting lamp on recipient's telephone.
Recipient sees message waiting lamp is on, and retrieves message slips from message mailbox.	Recipient sees message waiting lamp is on and dials the Lite system to retrieve messages.
Recipient reads messages left on message slips.	The Lite system plays messages recorded by callers in the voice mailbox.

1.2 Understanding the Lite System Product Design

The Lite system is designed using the Box concept. A box contains a set of instructions that tell the program what to do with a call it is handling. By setting up the system to send calls to different boxes created on the system, you can have it effectively process calls—including playing certain prompts or greetings to callers, collecting information and messages from callers, and routing calls to certain extensions based on digits dialed by callers.

The Lite system product uses the same software base as other VP system products, but it is limited in the number of boxes you can set up on the system. These limitations effectively position the Lite system as a product for smaller businesses needing a simple, reliable voice mail system without all the advanced features of a larger, more expensive system. As the needs of Lite system users expand, they can obtain efficient, no-data-loss upgrades to other VP system voice processing products through an inexpensive and sensible upgrade plan.

Depending on the configuration purchased, the Lite system provides 5 Routing boxes and 25 mailboxes or 5 Routing boxes and 50 mailboxes. The Routing boxes are used to answer incoming calls, play a listing of options to callers, and route the call to a specific mailbox based on the digits dialed by the caller. The mailboxes transfer calls to their associated extensions and store messages for system subscribers, and they can be set up to forward calls to another phone or extension number, deliver messages to another phone or pager, play one of 9 pre-recorded greetings to callers, screen calls, queue calls when the extension is busy, or record call conversations.

Note: Lite systems also include 5 each of other box types including ACD, Group, Question, and Account Number boxes. These boxes provide more advanced functionality that may be port-intensive and therefore inappropriate for Lite system applications. For information on using these box types, refer to the *VP System Installation and Maintenance Manual*.

2. System Setup Instructions

The Lite system contains a default database with a setup configuration that allows the Lite system to efficiently perform fundamental call processing tasks with minimal system adjustments by the installing technician. This default database configuration includes 2 pre-defined classes of service (0 and 7), 1 supervisor mailbox (mailbox 70), and 3 Routing boxes—800, 801, 821. Information provided in this document explain how these pre-set defaults function on the Lite system.

As you proceed through these setup instructions, you may decide to make adjustments to specific information relating to the default setup. You may even decide to set up the other 2 available Routing boxes to perform additional call routing tasks. As you make any changes, keep in mind that we urge you to maintain the initial general configuration of Routing boxes 800, 801, and 821, class of service 7, and supervisor mailbox 70. This configuration allows the Lite system to efficiently perform fundamental call processing tasks. Maintaining it helps both you, the technician, and Lite system technical support to efficiently service the system and resolve any call processing issues. For these reasons we urge you not to deviate from this general system setup default configuration.

Information on setting up and using box types other than Routing boxes and mailboxes is provided in the *Installation and Maintenance Manual*.

<p>Note: Section 2.6 provides an overview of the default database setup shipped on Lite system units.</p>
--

2.1 Available System Setup Techniques

There are two techniques you can use to set up Lite systems:

- Attach a laptop to the Lite system unit and use the program's screen interface to complete System Information and Box Setup screens

- Call into the Lite system and use the Teleparameter feature to run the System First Time Setup utility then enter parameter codes and corresponding values to set up system and box information

This document provides instructions for using either system setup technique.

Note: Small Office Lite–Star systems include a video card and keyboard hookup, allowing you to attach a monitor and keyboard to the unit to work with the program’s screen interface—as you would by attaching a laptop to Lite systems that do not have a video card and keyboard hookup. Be advised that if you attach a monitor and keyboard directly to the unit, you do not need to follow the instructions in this document on using KeyLink software to establish a communication link between an attached laptop and the Lite system.

Technicians who have experience setting up Corporate Office, VVP, Small Office, or Lite systems may prefer to use the Teleparameter feature to quickly make modifications and get the Lite system up and running at the customer’s site. Be advised, however, that since this technique involves inputting codes that represent system parameters and corresponding values to which parameters are to be set, it is a bit more difficult to use effectively if you are unfamiliar with setting up Corporate Office, VVP, Small Office, or Lite systems. For this reason, we recommend that technicians unfamiliar with Corporate Office, VVP, Small Office, or Lite systems attach a laptop to the PC and use the instructions provided here to complete all necessary system setup steps through the screen interface.

Note: If you choose to set up the system using the Teleparameter feature, be sure to first review **section 2.5.6.2** and **2.6** so you clearly understand the setup of the default database included on the Lite system unit.

Note that if you choose to initially set up the system by connecting it to a laptop and using the screen interface, you can later make additional modifications by simply calling into the Lite system and using options on the Supervisor menu (see **section 3**) or using the Teleparameter feature (see **section 2.7.2**).

2.2 Preparing for System Setup

To install, set up, and maintain a Lite system voice processing system, you need the following equipment:

Equipment Needed

- **Lite system unit**
- **Portable diskette drive**
Should an unusual situation arise, it may be necessary for you to service the Lite system by attaching a portable diskette drive to the Lite system unit. Therefore, we strongly recommend that technicians servicing Lite system units have access to a portable diskette drive. (Small Office Lite-Star systems include a diskette drive.)
- **Authorization key (all Small Office Lite systems only)**
A Small Office Lite system operates fully only if the *authorization key* is attached to the PC's parallel port. This key is shipped in the packaging with the Lite system unit. To attach the authorization key, simply plug the key into the parallel port in the back of the PC. (Debut units do not require an authorization key.)



Authorization Key

If you choose to set up the system by connecting a laptop to the Lite system unit, you need the following additional equipment:

- **Laptop computer**

- **Null modem serial cable** (provided with the Debut units only)
- **KeyLink communications software** (provided with all Lite systems)

This additional equipment is necessary because the Lite system does not have a keyboard and monitor. To set up the system using a laptop, you must use a null modem serial cable to attach the laptop PC to the Lite system unit. So that the laptop computer can communicate with the Lite system unit, you must install KeyLink communication software, provided with the Lite system, onto the laptop PC. The KeyLink installation procedure is provided in this document.

Once the system is set up and tested, the system supervisor on-site can maintain the day-to-day aspects of the system (adding, deleting, modifying mailboxes; modifying greetings and call routing; etc.) by simply calling into the system using a telephone. No special Teleparameter modification instructions or laptop computers are necessary for regular daily maintenance of the Lite system.

2.3 Connecting the Lite System Unit to the Telephone System

The Lite system unit can be connected directly to local telephone lines, typically Centrex service, or behind a Key System or PBX.

2.3.1 Connecting Directly to the Central Office (C.O.)

The Lite system unit can be connected directly to the telephone lines as shown below.

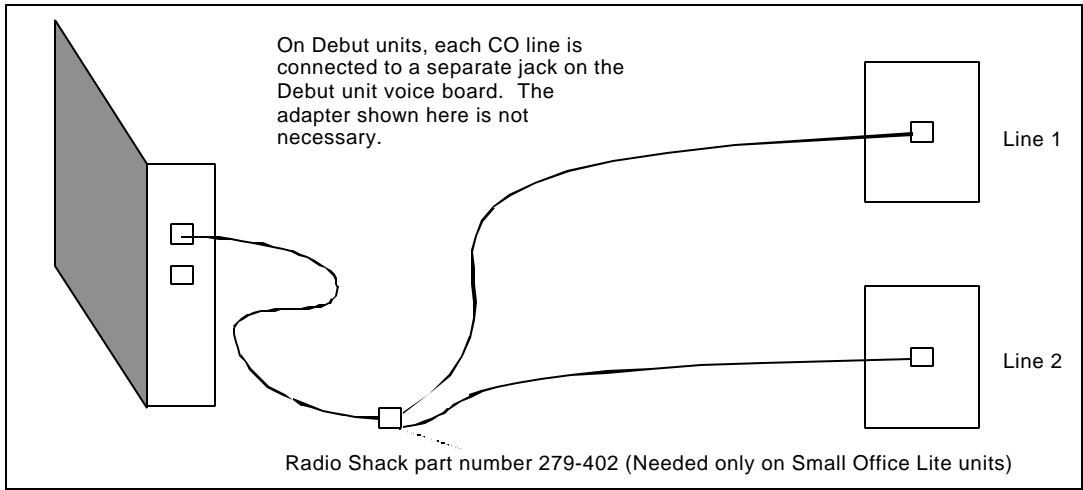

Connecting the Lite System Directly to Telephone Lines

Note that on Small Office Lite units, the modular input connectors on the voice boards are RJ-14 jacks which contain two independent telephone lines. The modular adapter shown (or its equivalent) must be used if the telephone lines are terminated with RJ-11 (single line) jacks. This adapter is not necessary on Debut units, where the modular input connectors on the voice boards are RJ-11 jacks.

If you want the Lite system to be able to transfer calls, make sure the telephone line has either the call-transfer or three-way calling feature. If you are unsure whether the lines have these capabilities, contact the local telephone company.

Local C.O. lines connected to the Lite system should *not* have the call-waiting feature assigned. Once again, if in doubt, contact the local telephone company.

2.3.2 Connecting the Lite System to a PBX or Key System

The Lite system unit connects to phone system station ports (each line to the Lite system unit looks like an extension to the phone system), as shown in the illustrations below. The Lite system thus functions as one or more extensions on the phone system.

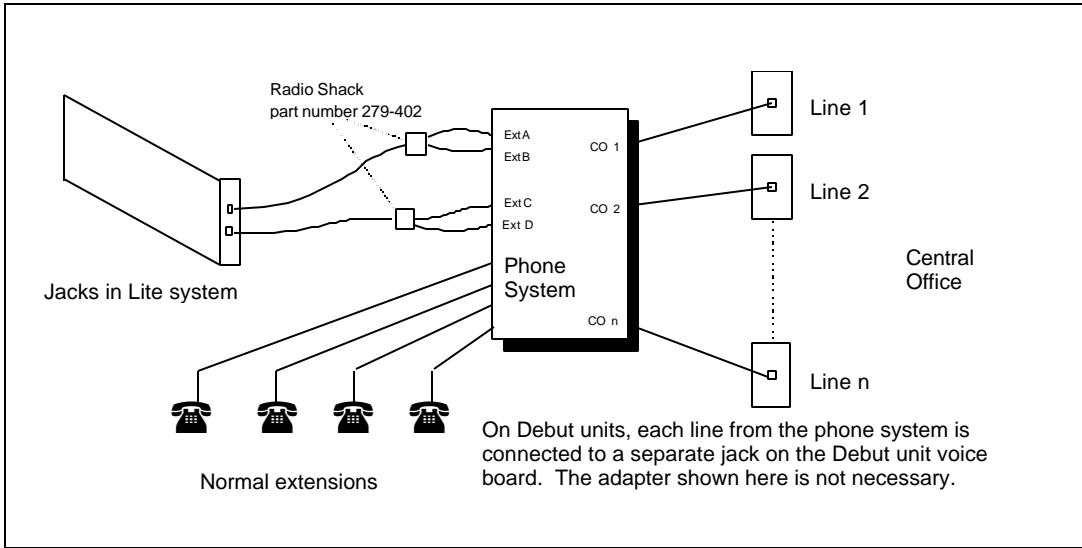

Connecting the Lite System Behind a Key System or PBX

Note that on Small Office Lite units, the modular input connectors on the voice boards are RJ-14 jacks, which contain two independent telephone lines. The modular adapter shown (or its equivalent) must be used if the phone system extensions are terminated with RJ-11 (single line) jacks. On Debut units, each line from the phone system is connected to a separate jack on the Debut unit voice board. The adapter shown here is not necessary.

Unless special digital voice boards are installed in the VP system unit, each line into the unit requires an industry-standard-telephone port on the phone system (this is also known by other names such as *analog port*, *2500 set interface*, *SLT port*). Some telephone systems do not provide single-line-telephone ports, and they require a special analog interface box between the phone system and the voice mail system, as shown below. If you have questions on the type of ports provided on the phone system, contact the local phone system manufacturer's representative. For information on digital voice boards, contact a VP system sales representative.

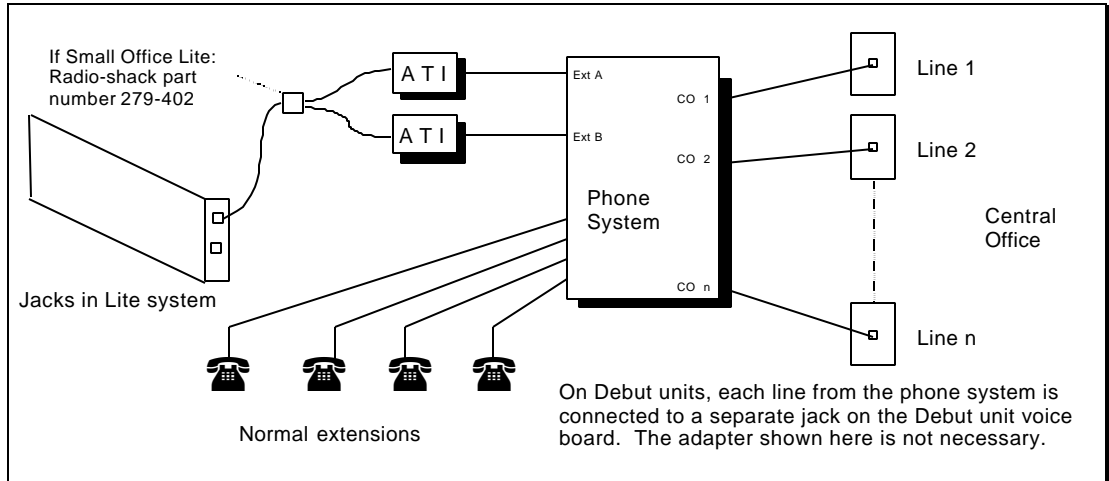

Connecting the Lite System to a PBX via External Analog Telephone Interface (ATI) Equipment

Connecting the Serial Cable Between the Lite System Unit and Phone System

If you are establishing a serial integration, you must attach a serial cable between the Lite system unit and the phone system. **Small Office Lite** system units are set up to use the COM 1 port to communicate with the phone system. Therefore, you should connect the serial cable to the unit's **COM 1** port. **Debut** system units are set up to use the COM 2 port to communicate with the phone system. Therefore, you should connect the serial cable to the **COM2** port on Debut units.

Consult the phone system documentation for instructions on attaching the serial cable to the phone system COM port.

Note: If the phone system you are working with is a Comdial DSU, attach the serial cable to **COM 1** on the DSU. If the phone system is a DSUII 8/16 or 16/32, attach the serial cable to **COM 3** on the DSUII. If the phone system is a DSUII 408, attach the serial cable to **COM1** on the DSUII.

Typical Setup

For typical automated attendant service, the phone system is programmed so that incoming calls are routed via the phone system to ring the Lite system. The Lite system answers the call and asks the caller to enter the required extension (or mailbox) number. The caller enters the number, and the Lite system transfers the call just as a live attendant would.

2.4 Collecting Necessary Customer Information

While setting up the Lite system, you may need to adjust default settings for the customer's regular business open hours and business closed hours. You also need to set up Routing boxes to handle incoming calls and set up mailboxes for subscribers who will be using the system. The following worksheets are provided to help the installing technician collect this information from the system supervisor.

Business Hours Worksheet

(System Supervisor Completes)

On the lines corresponding to each day of the week, write in 24-hour format (for example 8:00 PM is 20:00) the normal hours the company opens and closes for business. If the business is open 24 hours on a particular day, enter 0:00 as the **DAY SERVICE BEGINS** time and 24:00 as the **DAY SERVICE ENDS** time. If the business is closed the entire day on a particular day, enter 0:00 on both lines.

Indicate, if appropriate, any hour(s) during which the business closes during the day, for lunch or any other reason.

B U S I N E S S H O U R S				
	Day service begins	Day service ends	Lunch service begins	Lunch service ends
SUN:	_____	_____	_____	_____
Mon:	_____	_____	_____	_____
Tue:	_____	_____	_____	_____
Wed:	_____	_____	_____	_____
Thu:	_____	_____	_____	_____
Fri:	_____	_____	_____	_____
Sat:	_____	_____	_____	_____
Change "Good afternoon" to "Good evening" at: _____				

Specify the time of day the automated attendant should start answering calls with a "good evening" greeting.

Subscriber Mailbox Information Worksheet

(System Supervisor Completes)

Photocopy this page, then complete the form for each subscriber who is to have a mailbox.

Subscriber Data	
First name:	
Last name:	
Extension number:	
Should the system announce the caller's name to the subscriber upon transfer?	
Should all conversations be recorded?	
Paging Data	(complete only if subscriber is to use the feature)
Pager number	
Pager type (circle one)	TONE DIGITAL
Paging schedule (circle one)	Always During office open hours During closed hours Schedule*: A B C D
Auto Message Forward and Message Delivery Data	(complete only if subscriber is to use these features)
Auto forward new messages:	To box: _____ After _____ hours
Auto forward new messages schedule (circle one):	Always During office open hours During closed hours Schedule*: A B C D
Message delivery schedule 1:	Number to call: _____
When should delivery be active? (circle one):	Always During office open hours During closed hours Schedule*: A B C D

Continued on back

<p>Message delivery schedule 2: When should delivery be active? (circle one):</p>	<p>Number to call: _____ Always During office open hours During closed hours Schedule*: A B C D</p>
<p>Message delivery schedule 3: When should delivery be active? (circle one):</p>	<p>Number to call: _____ Always During office open hours During closed hours Schedule*: A B C D</p>
<p>Message delivery schedule 4: When should delivery be active? (circle one):</p>	<p>Number to call: _____ Always During office open hours During closed hours Schedule*: A B C D</p>
<p>Message delivery schedule 5: When should delivery be active? (circle one):</p>	<p>Number to call: _____ Always During office open hours During closed hours Schedule*: A B C D</p>

*If specifying a particular schedule, complete a subscriber schedule worksheet for the individual.

Subscriber Schedule Worksheet

(System Supervisor Completes)

Photocopy this page, then complete the form for each subscriber who is using the Paging, Auto Message Forwarding, or Message Delivery out-calling features according to a particular schedule, as indicated on his/her Subscriber Mailbox Information sheet.

You can designate up to 4 different schedules below, then apply one schedule to each out-calling feature the subscriber will be using. Enter information for 1 to 4 schedules below in 24-hour format (for example 8:00 PM is 20:00). You do not need to complete the **BOX NUMBER** field.

M A I L B O X Page 3					
Box number: _____		First Name: _____		Last: _____	
SCHEDULE A Start End SUN: _____ Mon: _____ Tue: _____ Wed: _____ Thu: _____ Fri: _____ Sat: _____	SCHEDULE B Start End Sun: _____ Mon: _____ Tue: _____ Wed: _____ Thu: _____ Fri: _____ Sat: _____	SCHEDULE C Start End Sun: _____ Mon: _____ Tue: _____ Wed: _____ Thu: _____ Fri: _____ Sat: _____	SCHEDULE D Start End Sun: _____ Mon: _____ Tue: _____ Wed: _____ Thu: _____ Fri: _____ Sat: _____		

Routing Worksheet (System Supervisor Completes)

Refer to **section 3.2** to familiarize yourself with the function of Routing boxes. This section also provides a sample of greetings that are typically recorded in the 3 Routing boxes pre-configured on the Lite system. After reviewing this information, complete this worksheet to indicate the wording for the greetings you want this Lite system to voice.

Note that you should indicate in your greeting any single-digit call routing options you want to provide to callers (“...*Press 2 for Sales...*”) and identify the extension to which a caller pressing that single-digit number should be transferred.

Office Open Greeting:

Single digit routing paths:

Office Closed Greeting:

Single digit routing paths:

Continued on back

Office Holiday Greeting:

Single digit routing paths:

2.5 Setting Up the System by Attaching a Laptop

Use the information in this section to complete all necessary system setup steps by attaching a laptop computer to the Lite system unit and using the Lite system's screen interface to complete System Information and Box Setup screens.

2.5.1 Installing Serial Administration Software on the Laptop

Serial administration features allow the Lite system unit (referred to as a *host* PC) to communicate with a laptop PC (referred to as a *remote* PC) through a null modem cable. While KeyLink software facilitates this communication from the host system, the software used to communicate from the remote PC depends on the remote PC's operating system. Starting with VP software version 8.3, serial administration software is available for both DOS-based and Microsoft Windows-based remote PCs. To establish communication between the host and a DOS-based remote unit, KeyLink software must be installed on both. To establish communication between the host and a Windows-based remote unit, KeyLink software must be installed on the host and Serial Administrator software must be installed on the remote.

KeyLink host software is pre-installed on the Lite system before it is shipped to you. The procedures detailed below outline the steps you follow to install the KeyLink or serial administration remote software on a laptop PC. Be sure to follow the proper procedure for your laptop's operating environment.

To install KeyLink for DOS on a DOS-based remote PC:

1. Insert the KeyLink installation diskette into the diskette drive on the PC.
2. At the prompt for the laptop's hard drive (typically C:\ or D:\), type A: INSTALL then press <Enter>.
3. Follow the prompts to install the Remote software and enter the requested information. When you are prompted to indicate the directory in which you want to install KeyLink files, accept the default directory \REMOTE. Accept program default setup selections whenever possible.

When all the necessary files have been copied, a message displays indicating that the installation is complete.

To install serial administration software on a Windows-based remote PC:

Note: The Windows-based PC must be running Windows 95, 98, 2000 or Windows NT.

1. Insert the first Serial Administration installation diskette (#1) into the diskette drive on the PC.
2. From the Start button, choose Programs, then Windows Explorer.
3. On the All Folders side of the Exploring screen, select the diskette drive (typically A:).
4. Double-click on SETUP.EXE from the right side of the Exploring screen.
5. Follow the prompts to install the remote software. When prompted to indicate the directory in which you want to install Serial Administration files, accept the default directory. Accept program default setup selections whenever possible.
6. When prompted, remove installation diskette #1 and insert diskette #2. Press OK. If the operating system on the laptop is Windows NT, after you remove diskette #1, you will receive an error message asking you to re-insert the disk. Instead, insert diskette #2, press the Retry button on the error message, and then select the Continue button.
7. When prompted, remove installation diskette #2 and insert diskette #3. Press OK. If the operating system on the laptop is Windows NT or Windows 2000, after you remove diskette #2, you will receive an error message asking you to re-insert the disk. Instead, insert diskette #3, press the Retry button on the error message box, and then select the Continue button.
8. When the Setup Complete screen appears, press Finish. A Serial Administration icon displays on the desktop.

2.5.2 Connecting the Laptop to the Lite System Unit

You connect the Lite system unit to the laptop computer using a null modem serial cable.

NOTE: Before connecting the null modem cable between the Lite system unit and the laptop, connect power to the Lite system unit and allow the unit to power up for 3 minutes or more. On the Debut unit, wait until the upper-most light on the right side of the unit (the light indicated by two curved arrows) starts to blink. This indicates that the VP system software is up and running. **After 3 minutes**, connect the null modem cable between the laptop and the Lite system unit, then attempt to establish communication using the procedure provided below.

When you install KeyLink or serial administration software on the laptop computer, the program defaults to using the COM 1 port on the laptop. Therefore, unless you change this default, you should connect one end of the null modem serial cable to the **laptop's COM 1** port. If you are communicating with a Small Office Lite system, connect the other end of the cable to the COM 2 port on the Small Office Lite unit. If you are communicating with a Debut system, connect the other end of the cable to the COM 1 port on the Debut unit.

Establishing a Communication Link Between a DOS-based Laptop and Lite System Unit:

1. To access the VP system program screens from a DOS-based remote PC, change to the \REMOTE directory then type REMOTE and press <Enter>.
2. A screen displays while the program loads and initializes communications. KeyLink then detects the baud rate set up on the host PC and establishes a compatible connection. This detection takes several moments.

Once KeyLink establishes a connection between the two systems, the screen refreshes with a display that shows the host PC. The keyboard and monitor of the remote computer now effectively control the host (VP system) PC.

NOTE: If a connection cannot be established between the host (VP system) PC and the remote PC, verify you specified the appropriate COM port settings during KeyLink installation. Also verify you are using a true **Null Modem** cable. Because it is difficult to visually distinguish null modem cables from other serial cables, some users mistakenly use the wrong cable type.

NOTE: If you are working with a Debut unit and still cannot establish a connection between the Host (Debut unit and the remote PC, unplug both the Null Modem cable connection at the Debut unit and the Debut unit power source. After a full 60 seconds, replug the Debut unit into the power source. Wait until the upper-most light on the right side of the unit (the light indicated by two curved arrows) starts to blink (this could take several minutes). Once the light is blinking, replug the Null Modem cable from the remote PC. A connection should now be able to be established.

To break the connection between the remote PC and the host (VP system) PC, press <Ctrl-Break> on the remote PC's keyboard. The KeyLink program ends its communication with the host (VP system) PC, and the remote PC's screen refreshes. To re-establish communication, repeat steps 1-2.

Note: If you type **EDIT** to invoke a DOS editor on the Lite system unit, you will invoke a special editor pre-installed on the unit. This editor was developed specifically for use with a null modem cable. (Traditional DOS editors cannot communicate effectively over a null modem cable.)

Note: For information on transferring files between the Lite system and the attached PC, refer to section 10 of the *Installation and Maintenance Manual* or contact technical support.

Establishing a Communication Link Between a Windows-based Laptop and Lite System Unit:

1. From the remote PC Windows desktop, click on the Serial Administration icon. The VP system serial administration program loads and the SERIAL ADMINISTRATOR screen displays.
2. From the File pull-down menu, select the CONFIGURE PORTS option. The CONFIGURE SERIAL CONNECTION screen displays.
3. Verify that the COMPORT field indicates the port to which the null modem cable is attached on the remote PC. Also confirm that other COM port information is specified correctly and corresponds with the information in the USE REMOTE DBA line in the host VM.CFG file. Select the OK button. You return to the SERIAL ADMINISTRATOR screen.

From the SERIAL ADMINISTRATOR screen you can work with the VP system host PC two ways:

- Use KeyLink to view and work with the VP system's DOS screen interface.
- Through a Windows interface to the DOS-based VP system. The windows interface will allow you to control much but not all of the VP system functionality. You will need to use KeyLink to select options or program components that are not available through the Windows interface.

To use KeyLink to view and work with the VP system's DOS screen interface, from the KeyLink pull-down menu, select the REMOTE CONTROL option. Once KeyLink establishes a connection between the two systems, the screen refreshes with a display that shows the host PC. The keyboard and monitor of the remote computer now effectively control the host (VP system) PC. The screens you view show the setup and functionality of the VP system host PC, and the keystrokes you make affect the functionality of that PC.

To use a Windows interface to the DOS-based system, from the File menu, select the CONNECT option. Once a connection is established between the systems, the Boxes, System, Diagnostics, and Help pull-down menus are activated on the SERIAL ADMINISTRATOR screen. Using options available on these Windows-based menus, you can modify the system and box setup structure on the VP system PC. For information on using specific options, select options from the Help pull-down menu.

To break the connection between the remote PC and the host (VP system) PC, select the Exit option from the File pull-down menu.

Note: If a connection cannot be established between the host (VP system) PC and the remote PC, verify that you specified the appropriate COM port settings during KeyLink installation. Also verify that you are using a true **Null Modem** cable. Because visually distinguishing null modem cables from other serial cables is difficult, some users mistakenly use the wrong cable type.

Note: It is important to note that the Windows interface to the VP system is based on an NT-based version of VP system software. These NT-based VP systems contain an interface very similar to that provided through the Boxes, System, and Diagnostics pull-down menus on the Serial Administrator screen. For this reason, the Windows interface Help menu contains the information provided with NT-based VP systems.

Note: Some Serial Administrator windows will not fit screens using a resolution of less than 800 x 600.

2.5.3 Completing the First Time Setup Procedure

Once you connect the Lite system to the phone system and access the Lite system using a laptop computer, you are ready to begin customizing the system. Customizing the system involves:

- Running the First Time Setup utility
- Specifying System Information
- Specifying Routing Box and Mailbox Information

2.5.4 Running the First Time Setup Utility

The Lite system voice processing software is pre-installed on the Lite system unit before it is shipped to you. You must, however, run the First Time Setup utility so you can specify the phone system to which the Lite system is connected and configure certain installation parameters for each customer's site.

You run the First Time Setup utility using the teleparameter feature. See **section 2.7.1** and **section 2.7.1.1** for procedures. Once you run the utility, continue with **section 2.5.5** for instructions on specifying system information.

2.5.5 Specifying System Information

System Information screens contain system setup information that applies system-wide, to all boxes set up on the system. There are six System Information screens:

- General Information Screen
- Line Information Screen
- Business Hours Screen
- Call Transfer Screen
- Class of Service Screen(s)

- Other Customizations Screen

Before you set up Routing boxes and mailboxes, it is best to ensure all System Information screens are properly completed.

Note: Because the default information on System Information screens is set so the Lite system is operational with as few changes as possible, the procedures provided in this document for entering data on System Information screens do not go into detail about all the screen entries. Instead, the procedures guide you through accessing and reviewing pertinent fields on certain screens, so you can verify that default data is properly set and modify it if absolutely necessary. If you need to make additional changes to the System Information screens, refer to information provided in the *Installation and Maintenance Manual*.

Note that you can access online help at any time by pressing <F1>.

2.5.5.1 Integration Defaults Set by the Integration Program

When you run the First Time Setup utility (previous procedure), you are prompted to indicate the type of telephone system the customer is using. If you are installing the Lite system on one of the phone systems identified below, the Integration program automatically sets fields on several System Information screens to the phone system's default settings. Unless you customize the phone system defaults, you probably do not need to modify these settings. (Note that integration data for some phone systems is not available with Debut. See section 2.7.1 for more information.)

- Atlas 50 / 200
- Comdial DigiTech / Impact / DSU
- Comdial DXP / DXP Plus
- Comdial FX / FXS / FXT
- Comdial Executech 2000
- Comdial Unisyn
- Cortelco Aries
- Encore CX - ECX 1832 / 3672 / 36112
- Ericsson MD-110
- Fujitsu 9600 with Serial Integration

- Fujitsu Allegra 26
- Fujitsu Series 3 / Starlog
- Fujitsu Starlog
- Harris 20/20
- Harris Intellicom 500
- Harris Intellicom 2000
- Hitachi HCX 5000
- Intertel GX152D
- Isoetec IDS 108 / 228
- Isoetec System 96
- ITT / Cortelco System 3100
- ITT ECS 4.02P
- ITT ECS 6.3
- Iwatsu ADIX
- Iwatsu ZT-D
- Lucent Definity G3 – Calista Box – Vectoring – Bridged Mode
- Lucent Definity G3 – Inband – No VoiceBridge
- Lucent Definity G3 – VoiceBridge
- Lucent Definity G3 – VoiceBridge – Vectoring – Bridged Mode
- Lucent Definity G3 – Calista Box – Vectoring – Bridged Mode
- Lucent Definity Pro Logic
- Lucent Merlin II
- Lucent Merlin Legend
- Lucent Partner ACS
- Lucent Partner Endeavor
- Lucent Partner II
- Lucent Partner Plus
- Lucent System 25
- Lucent System 75
- Lucent System 75 – VoiceBridge
- Lucent System 85 and Definity Generic 2 – Voice-Bridge
- Mitel COV with D/42D-SX Voice Boards
- Mitel SX100 Digital PABX with ONS Integration
- Mitel SX200 Light with COV Integration
- Mitel SX200 Light with DNIC Integration
- Mitel SX200 Light with DNIC – Calista 4X4 Integra-tion
- Mitel SX200 Light with ONS Integration
- Mitel SX200D with COV Integration

- Mitel SX200D with ONS Integration
- Mitel SX2000 and SX2000 Light with COV Integration
- Mitel SX2000 and SX2000 Light with DNIC Integration
- Mitel SX50 with COV Integration
- Mitel SX50 with DNIC Integration
- Mitel SX50 with DNIC – Calista 4X4
- NEC Electra Professional Level I
- NEC Electra Professional Level II
- NEC Mark II
- NEC NEAX-1400 IMS
- NEC NEAX-2000
- NEC NEAX-2400 Serial Integration
- Nitsuko DSO-1 / ONYX / 124i / 384I
- Northern Telecom Meridian 1 – Calista Box – Vectoring – Bridged Mode
- Northern Telecom Norstar – Calista 4X4
- Northern Telecom Norstar - With VMI Adapters
- Northern Telecom SL-1 and Meridian-1/SL-1 (with D42-SL)
- Panasonic 1232 - Analog
- Panasonic DBS
- Panasonic KXT-336
- Panasonic KX-TD 1232 Digital
- Panther II 820 / 1032 / 2064 Release IV
- Philips SOPHO-S
- Premier ESP / Intertel GMX
- Redwood 3.2
- Rolm 8000 Series CBX – VoiceBridge
- Rolm 9000/9751 Series CBX – VoiceBridge
- Rolm 9200 BCS / Siemens HCM 200
- Samsung Prostar 56EX / 120MX / 1224
- Samsung Prostar DCS - Digital
- Siemens Saturn I, II, III
- Siemens Hicom 150
- Siemens Hicom 150 E
- SMDI Installation Guide / Centrex (Lite system only)
- Southwestern Bell Landmark DKS 308 / 616
- Sprint Protégé / Macrotel MT360 / 824 KSU
- SRX
- Sun Moon Star

- Tadiran Coral I, II, & III with SMDI
- Tadiran Coral I, II, & III – E&M – Inband with Voice Pro
- Tadiran Coral 9.87
- Telrad 2464
- Telrad Digital Key BX, 200 Digital
- Toshiba DK-16 / 24 / 56 / 96
- Toshiba DK-280
- Toshiba Perception E
- Toshiba Perception EX
- Toshiba Perception I & II
- Toshiba Strata E
- Vodavi DHS
- Vodavi Infinite DVX1, DVX2, & DVX3
- Vodavi Starplus 2448EX / 4896EX
- Vodavi Starplus 96EX
- Vodavi Starplus Digital
- Win 100D

If you are using a telephone system that is not listed here, the Integration program sets fields on System Information screens to commonly used defaults. You may need to adjust these settings.

For detailed information on integrating the Lite system with the phone system, refer to both the *Installation and Maintenance Manual* and the technical bulletin for the phone system.

2.5.5.2 Using Technical Bulletin Information

For almost every telephone system supported by the VP system, there is a technical bulletin that details telephone-specific installation considerations and telephone-specific default values that are pre-set on System Information screens when you run the First Time Setup utility. This information is particularly useful if you are working with a phone system that is not specifically listed when you run the First Time Setup utility—primarily because it is more likely you will need to adjust settings on System Information screens.

You can obtain technical bulletins in the Dealers Only area of the web site WWW.KEYVOICE.COM or via fax distribution. To access bulletins via fax, phone (941) 922-3800 and press 7 at the main greeting. Follow the system prompts and, when requested, enter

the number corresponding to the bulletin for the phone system with which you are working. To obtain a listing of all available bulletins and their associated bulletin numbers, request document **01**.

2.5.5.3 Accessing System Information Screens

1. From the Line Status screen, **press <F10>**. The Main menu displays, and you are prompted to enter a system password.
2. At the prompt to enter the system password, press <Enter>. (The default Customer level password is blank. The default Technician level password is **1234**.)
3. From the Main Menu, select **SYSTEM INFORMATION**. The System Information menu displays.

2.5.5.4 Setting Up the General Information Screen

1. From the System Information menu, select **GENERAL**. The General Information setup screen displays.
2. Press <Enter> to move the cursor to the **AUTOMATICALLY EXIT TO DOS AT** field. **Enter the time** at which the Lite system should exit to DOS to perform its auditing functions. The default setting is 3:00 AM.
3. To save the information and exit the screen, **press <F10>**. The System Information menu displays.

2.5.5.5 Setting Up the Line Information Screen

1. From the System Information menu, select **LINE INFORMATION**. The Line Information setup screen displays. Each row on this screen corresponds to one line connected to the Lite system.
2. Press <Enter> to move the cursor to the Initial Box field under Day Service for line 1. Verify that **800** displays in this field, indicating that calls received during Day Service hours are to go to Routing box 800.

3. Press <Enter> to move the cursor to Initial Box field under Night Service for line 1. Verify that **801** displays in this field, indicating that calls received after the day service hours are to go to Routing box 801.
4. Press <Enter> to move the cursor to the Initial Box field under Lunch Service for line 1. Verify that **800** displays in this field, indicating that calls received during Lunch Service are also to go to Routing box 800.
5. Press <Enter> to move the cursor to the **OUTGOING ALLOWED** field for line 1. Verify this field is set to **No**.
6. Repeat steps 3 through 5 for each line on the screen. For the last line, however, be sure to verify that **Yes** in the **OUTGOING ALLOWED** field.
7. To save the information and exit the screen, **press <F10>**. The System Information menu displays.

2.5.5.6 Setting Up the Business Hours Screen

1. From the System Information menu, select **BUSINESS HOURS**. The Business Hours setup screen displays.
2. For each day of the week, enter the **office opening time** in the **DAY SERVICE BEGINS** field and the **office closing time** in the **DAY SERVICE ENDS** field. The default is an office open time of 8:00 AM and office closing time of 17:00 (5:00 PM). If you want calls to be handled in the same way day and night, enter **00:00** in the **DAY SERVICE BEGINS** field, and **24:00** in the **DAY SERVICE ENDS** field. Refer to the Business Hours Worksheet completed by the system supervisor for specific information.
3. To save the information and exit the screen, **press <F10>**. The System Information menu displays.

2.5.5.7 Setting Up the Call Transfer Screen

1. From the System Information menu, select **CALL TRANSFER**. The Call Transfer setup screen displays.

2. The fields in the top half of the screen list the sequences that the Lite system is to dial to transfer calls (the “!” signifies *hook-flash* and the comma signifies *pause for one second*). Typically, these settings are appropriate for most telephone systems without any modification. If you *know* the actual sequences required by the telephone system, and they are different from those shown, make the changes as necessary.
3. To save the information and exit the screen, **press <F10>**. The System Information menu displays.

2.5.5.8 Setting Up the Class of Service Screen

Each mailbox on the system is assigned a class of service. The class of service assigned to the box dictates which Lite system features the mailbox owner has access to and how he/she can use those features.

There are 8 classes of services (0 through 7) that can be set up then applied to mailboxes on the Lite system. Two of them are pre-configured on the system. Class of service 0 is assigned by default to the prototype mailbox 9994, which serves as a template for every mailbox that you create on the system. Class of service 7 is assigned supervisor mailbox privileges. This class of service is assigned to mailbox 70, which is also pre-configured on the system. Mailbox 70, therefore, serves as the supervisor mailbox. By calling into the system and accessing the supervisor mailbox, the system supervisor can make necessary day-to-day modifications to the voice processing system, such as adding mailboxes, changing Routing box greetings, etc. See **section 3** for details.

1. From the System Information menu, select **CLASS OF SERVICE**. The Class of Service setup screen displays.
2. Use the information provided below to review and, if necessary, adjust the fields on two different Class of Service screens. First, review class of service 0, which functions as the class of service that will be assigned to subscriber mailboxes on the system. When you reviewed the screen for class of service 0, **press <F6>** to progress through the classes of service and go to the setup screen for class of service 7.

Review and, if necessary, adjust class of service 7. Ensure that in class of service 7 the **SUPERVISOR STATUS?** field is set to **Yes**. This allows the owner of the mailbox assigned this class of service to access the Supervisor menu over the telephone. Using this menu, the system supervisor can call into the system to perform day-to-day maintenance on the system.

C L A S S O F S E R V I C E			
Class-of-service number: <input type="text" value="0"/>		CLASS-OF-SERVICE NAME: <input type="text" value=""/>	
Maximum number of greetings: <input type="text" value="1"/>		Maximum greeting length (secs): <input type="text" value="60"/>	
Maximum number of messages : <input type="text" value="200"/>		Maximum message length (secs): <input type="text" value="60"/>	
Auto-delete OLD messages from system after <input type="text" value="30"/> days.			
Auto-delete NEW messages from system after <input type="text" value="99"/> days.			
Supervisor status ?	<input type="text" value="No"/>	Play menu after greeting?	<input type="text" value="No"/>
Access to Group-boxes ?	<input type="text" value="Yes"/>	Allowed to receive faxmail?	<input type="text" value="No"/>
Dial-out allowed?	<input type="text" value="No"/>	Operator Box (Day):	<input type="text" value="888"/> (Night): <input type="text" value="888"/>
Access to P.A.?	<input type="text" value="Yes"/>	When exiting open Mail Box, go to box	<input type="text" value="821"/>
Max lines allowed to hold for one box: <input type="text" value="2"/>		Digits allowed while holding: <input type="text" value=""/>	
While in queue, say position in line? <input type="text" value="No"/>			
Try extension <input type="text" value="3"/> times, before going back to caller.			
R E S T R I C T E D N U M B E R S			
Digits: <input type="text" value=""/>	Digits: <input type="text" value=""/>	Digits: <input type="text" value=""/>	Digits: <input type="text" value=""/>
Digits: <input type="text" value=""/>	Digits: <input type="text" value=""/>	Digits: <input type="text" value=""/>	Digits: <input type="text" value=""/>
F1=Help		F5=Previous COS	
F6=Next COS		F10=Exit	

CLASS OF SERVICE NUMBER

This field indicates the number of the class of service you are currently working with. To move to the next class of service number, press <F6>. Once you assign a class of service to a mailbox, the mailbox inherits all the privileges and restrictions defined in the class of service.

CLASS OF SERVICE NAME

Use this field to give the class of service a meaningful name. This helps remind you of the purpose for the class of service. Sample names include *Supervisors*, *Subscribers*, etc.

MAXIMUM NUMBER OF GREETINGS

A mailbox can have up to 10 pre-recorded personal greetings. The mailbox owner may record these greetings, store them in the mailbox, then choose the greeting that is to be active at any specific time. You may want to offer use of all 10 greetings to users or restrict them to fewer greetings. Use this field to define how many personal greetings users with this class of service should be allowed to record. If you set the field to 0, then callers who route to a

mailbox belonging to this class of service always hear the pre-recorded system prompt, *"That extension is not available..."* The default setting is **10**.

Note that in class of service 7, this field must be set to allow at least 2 greetings. Class of service 7 is assigned to mailbox 70, the supervisor mailbox that controls the Routing boxes on the system. Because you will be setting up these Routing boxes with at least 2 greetings, this parameter must be set to at least **2** in the supervisor mailbox class of service.

MAXIMUM GREETING LENGTH

When a mailbox owner calls in to re-record his/her personal greeting, the Lite system limits the length of the new greeting to the value entered in this field. The default setting is **60**.

MAXIMUM NUMBER OF MESSAGES

The Lite system can hold up to 200 messages per mailbox. However, you may want to restrict some mailboxes to a lower limit (to conserve disk space). Use this field to define the maximum number of messages that can be stored in mailboxes assigned this class of service. Once the limit is reached for a particular mailbox, callers attempting to leave more messages in the mailbox are told that the box is full. The default setting is **200**.

MAXIMUM MESSAGE LENGTH

The value in this field defines the maximum length of a message (in seconds) that a caller can leave for mailboxes belonging to this class of service. The default setting is **60**.

AUTOMATICALLY DELETE OLD MESSAGES FROM SYSTEM AFTER X DAYS

The Lite system deletes messages saved as Old from mailboxes belonging to this class of service after the number of days you specify. An old message is one the mailbox owner has listened to, but has not yet deleted. If you enter **0** in this field, an old message is deleted at midnight on the day the message became old. If you enter **1** in this field, an old message is deleted at midnight on the day following the day the message became old.

To disable deletion of Old messages, enter **99** in this field. However, do this with caution, since accumulating messages may create disk storage problems. The default setting is **30**.

AUTOMATICALLY DELETE NEW MESSAGES AFTER X DAYS

<p>Note: Use this parameter with caution. Improper use may cause important messages to be lost.</p>
--

The Lite system deletes new messages from mailboxes belonging to this class of service after the number of days you specify. A new message is one the mailbox owner has not yet listened to. If you enter **0** in this field, a new message is deleted at midnight on the day the message was received. If you enter **1** in this field, a new message is deleted at midnight on the day following the day the message was received.

To disable the deletion of new messages, retain the default setting of **99** in this field. This is the default operating mode. If you enter a number other than 99 in this field, remember that messages are deleted whether or not the mailbox owner has listened to them.

SUPERVISOR STATUS

This field defines whether mailboxes belonging to this class of service should have supervisor privileges. A supervisor can perform certain actions not available to regular mailbox owners. For example, a supervisor can add a mailbox or delete a mailbox by calling in from any telephone. Additional information on supervisor functions is provided in **section 3**. The default setting in class of service 0 is **No**, in class of service 7 is **Yes**.

ACCESS TO GROUP BOXES

By setting this field to **Yes**, you allow subscribers assigned this class of service to access any Group boxes set up on the system. For information on setting up and using Group boxes, refer to the *Installation and Maintenance Manual*. The default setting is **Yes**.

DIAL-OUT ALLOWED

This field indicates whether the owner of a mailbox belonging to this class of service is allowed to place outgoing calls from the mailbox. The default setting is **No**.

ACCESS TO P.A.

When a caller is listening to a mailbox owner's greeting, one of the features the Lite system offers is the option to have the call announced over the P.A. system. Use this field to allow

or deny access to the P.A. feature for callers to mailboxes belonging to this class of service. The default setting is **Yes**.

PLAY MENU AFTER GREETING

If an extension is busy or does not answer, the Lite system plays the mailbox owner's personal greeting. After playing the greeting, it can announce the options available to the caller (for example, *"If you would like to leave a message, press 1. To try another extension, press 3, or to speak with an operator, press 0."*). If the mailbox owners do not record these options as part of their greetings, set this field to **Yes** so that the Lite system plays the menu. If you want to allow each mailbox owner to decide which options to offer, set this field to **No** and instruct each mailbox owner to include the options in his/her personal greeting. The default setting is **No**.

ALLOWED TO RECEIVE FAXMAIL

The Lite system users should retain the default setting **No** in this field.

OPERATOR BOX (DAY) (NIGHT)

When a caller is listening to a mailbox greeting, one of the options is to dial zero to reach an operator. Use these fields to indicate the mailbox to which the call should be routed if the caller indicates that he/she wishes to speak with an operator. The default setting is **888**.

WHEN EXITING OPEN MAILBOX, GO TO BOX

When a mailbox owner has logged in to his/her box, has concluded listening to messages, changing options, etc., and has selected to exit from the Main menu, this field tells the Lite system where to send the call. The Lite system users should retain the default setting in this field as **821**.

MAX LINES ALLOWED TO HOLD FOR ONE BOX

You can limit the number of lines that can simultaneously hold for a mailbox belonging to this class of service. For example, if you set this number to 3, and lines 1, 3, and 6 are holding for a mailbox, then subsequent callers are not offered the option to hold. Instead, they hear the personal greeting recorded for the box, so they can leave a message, try another extension, etc. The default setting is **2**.

Note: If you want to disable the Call Queuing feature for the class of service, set this field to **0**.

DIGITS ALLOWED WHILE HOLDING

While a caller is in the queue holding for an extension, he/she can press a digit to leave the queue and process the call differently. By default, the options open to the caller are the same as those available when the caller hears the personal greeting ("*If you would like to leave a message, press 1. To try another extension, press 3, or to speak with an operator, press 0.*"). If you want to restrict the caller to fewer choices while in the queue, use this field to specify which digits are allowed. All other digits are ignored by the Lite system while the caller is in the queue. For example, if you enter 13 in this field, the only options available to the caller are:

- 1 To leave a message
- 3 To try another extension

WHILE IN QUEUE, SAY POSITION IN LINE

While a caller is in the queue, holding for an extension, the Lite system can keep him/her informed on the progress of the call. If you set this field to **Yes**, the Lite system announces to the caller:

"That extension is still busy. You are number [x] in line. If you would prefer to leave a message, press 1, or to speak with an operator, press 0."

If you select **No** in this field, the Lite system voices:

"That extension is still busy. If you would prefer to leave a message, press 1, or to speak with an operator, press 0."

The default setting is **No**.

TRY EXTENSION X TIMES, BEFORE GOING BACK TO CALLER

This parameter applies only if the **MAX LINES ALLOWED TO HOLD** field is greater than 0. If the caller chooses to hold, the Lite system plays a series of hold prompts to the caller (these are typically music or commercials). At the end of each hold prompt, the Lite system tries the extension again. If it is busy, then the next hold prompt is played to the caller.

After the defined number of hold prompts have been played, the Lite system goes back to the caller and offers the options to remain on hold, try another extension etc. This field allows you to specify the number of hold prompts that should be played before the Lite system offers these options to the caller.

As shipped, the Lite system has only one hold prompt recorded (system prompt #146, see the *Installation and Maintenance Manual*). Therefore, if you enter 3 in this field, a caller queued to a busy station hears this same prompt three times before being offered the options again. If you record the second hold prompt (#147), then the caller hears prompt # 146, #147, then #146 again before being offered the options. You may record up to 100 different hold prompts, which are played in sequence. (Remember: At the end of *each* hold prompt, the Lite system tries the extension again). After the Lite system plays the highest number hold prompt recorded, it returns to the lowest number after the next try. The default setting is 3.

<p>Note: The time between tries to a busy extension is determined by the length of each hold prompt recorded. The prompt supplied with the Lite system (#146) is approximately 30 seconds.</p>

RESTRICTED NUMBERS

When a mailbox owner calls in to change his/her call-transfer number, pager number, or message notification number, you may want to prevent him/her from changing it to certain numbers, such as long-distance numbers.

These fields allow you to define digit sequences that are to be blocked. The Lite system looks at each of these Digits fields to determine if any of them match the number entered by the mailbox owner. If the number entered by the caller begins with the digits specified in the Digits field, the Lite system defines the number entered as a match.

For example, if you enter the digits 1900 in one of the Digits fields, the Lite system considers 1-900-555-1212, 1-900-123-4567, 1-900-111-2222 to be matches. Telephone number 1-901-555-1212 would not be considered a match.

If you enter the digit 0 in one of the digits fields, the Lite system considers all numbers beginning with 0 to be matches. This would include calls to the operator (0), calls to the long-distance operator (00), international calls (011), and any operator-assisted call (0 followed by telephone number).

If the caller enters a number that matches one of the digit strings you enter here, the Lite system informs the mailbox owner that the number is not acceptable and retains the current set up.

Once you review and adjust all fields on both Class of Service setup screen 0 and Class of Service setup screen 7, **press <F10>** to save the information and exit. The System Information menu displays.

You have now reviewed the necessary entries on the System Information screens. To return to the Line Information screen, **press <F10>**.

2.5.6 Specifying Box Information

2.5.6.1 What Is a Box?

When the Lite system answers a call, it processes it by sending it to a *box*. Each box performs a specific function (for example, playing a menu to the caller and waiting for a response). It then passes the call to another box, which in turn performs its specific function, etc.

Depending on the configuration purchased, the Lite system provides 5 Routing boxes and 25 mailboxes or 5 Routing boxes and 50 mailboxes. The Routing boxes are used to answer incoming calls, play a listing of option to callers, and route the call to a specific mailbox based on the digits dialed by the caller. The mailboxes transfer calls to their associated extensions and store messages for system subscribers, and they can be set up to forward calls to another phone or extension number, deliver messages to another phone or pager, play one of 9 pre-recorded greetings to callers, screen calls, queue calls when the extension is busy, or record call conversations.

2.5.6.2 Understanding Routing Box 800, 801, and 821

According to the entries specified on the Line Information screen, the Lite system will route all incoming calls to Routing box 800. This box answers calls during the day and lunch service hours and plays a greeting to callers. After day/lunch service hours, the system routes

calls to Routing box 801. Typically, companies offer more extensive call routing options to callers during day/lunch service hours than during closed hours. Often, for example, single-digit call routing (“...*Press 2 for Sales...*”) is not offered during closed hours. Therefore, the greeting voiced by and options available in Routing box 801 are often different than those in Routing box 800.

So that the system supervisor can alter the system to voice a generic holiday greeting on holidays the office is closed, you will set up both Routing box 800 and 801 to include a holiday greeting alternative. Therefore, procedures in this document guide you through recording two greetings in both boxes 800 and 801: an office open greeting and a holiday greeting in box 800, and an office closed greeting and a holiday greeting in box 801. (Keep in mind that holidays last 24 hours, therefore calls received on a holiday may be processed by either box 800 or 801, depending on when the call is received. For this reason, a holiday greeting must be recorded in both box 800 and 801). Sample greetings for these boxes are provided in **section 3.2.1**.

Routing Box 821 is designed by default to take over and route calls once they have passed through Routing box 800 or 801. A call may go to Routing box 821, for example, after the caller leaves a voice message in a subscriber’s mailbox. Routing box 821 offers callers a menu similar to Routing box 800, but box 821 is pre-configured so if a caller does not enter an extension or select a menu option, the call is disconnected. In Routing box 800 and 801, callers who do not enter an extension or select an option are transferred to the operator. This is a safety measure designed to assist callers who use rotary phones or are too slow to respond to system prompts. By disconnecting non-responsive callers in box 821, the system simply assumes that the caller knew how to select menu options in box 800 or 801, and therefore, since no option was selected in box 821, the caller hung up.

Because we recommend you record two greetings in both Routing box 800 and 801, you will not use the **GREETING RECORDED** field on the Routing Box setup screens. This field allows you to record only one greeting for the Routing box. Instead you will record all necessary greetings by following the steps in the **section 2.5.6.9**, which you will complete after you review and set up the Routing boxes and mailboxes.

2.5.6.3 Accessing Box Information Screens

1. From the Line Status screen, **press <F10>**. The Main menu displays and you are prompted to enter a system password.
2. At the prompt to enter the **system password**, press <Enter>.

3. From the Main Menu, select **BOX INFORMATION**. The Box Information menu displays.

You should review the setup for the following boxes:

- Routing Box 800
- Routing Box 801
- Routing Box 821
- Prototype Mailbox 9994
- Supervisor mailbox 70

After you review and, if necessary, adjust prototype mailbox 9994, you use it to set up subscriber mailboxes. You then make necessary adjustments to these mailboxes to customize them for system subscribers. This section details the steps you must follow to set up all necessary boxes and make the required adjustments.

The following procedures identify screen setup entries necessary for the Lite system to effectively process calls. Fields that are not specifically discussed contain default values that should be appropriate in nearly all setup situations. Detailed information on all fields on Routing Box and Mail Box setup screens is provided in the *Installation and Maintenance Manual*. You can also access online help on any screen by pressing <F1>.

2.5.6.4 Reviewing Routing Box 800, 801, and 821 and Setting Up Single-Digit Call Routing

- From the Box Information menu, select **ROUTING BOX**. The Routing Box setup screen displays.

```

ROUTING BOX
-----
Box number : 800      BOX NAME :Main Greeting
Greeting recorded : No      Owner: 70
Number of times to play the greeting : 1
Number of seconds to wait for a digit: 1

If no digits dialed, Go to box ... - box 821
If invalid digit dialed, go to box 800
Route the call based on :Digit dialed
When digit received, wait for more digits? Yes
-----
Destination for digit 1 :      6 :      * : 9998
                        2 :      7 :      # : 9992
                        3 :      8 :
                        4 :      9 :      Voice:
                        5 :      0 : 888

```

- Press <F4> to access the box selection screen. A small window displays prompting you for the box number. Type 800 then press <Enter>.
- Press <Enter> to move the cursor moves to the **OWNER** field. So that more than one greeting can be recorded and stored for use with this Routing box, this box should be identified as being owned by the supervisor mailbox, mailbox 70. By specifying a mailbox owner for this Routing box, the box takes on certain “mailbox” attributes, which include being allowed to house the same number of greetings as the mailbox owner’s mailbox. (You specified this number when you set up class of service 7.)
- Press <Enter> to move the cursor to the **DESTINATION FOR DIGIT** fields. If you are setting up the system to provide single-digit call routing options to callers, complete these fields. Refer to the Routing Worksheet completed by the system supervisor for specific information on entries for these fields. Do not modify the **DESTINATION FOR DIGIT** * and # fields.

5. Repeat steps 2 through 5 to set up Routing box 821. In step 2, type **821** (instead of 800) to access box 821. In the **DESTINATION FOR DIGITS** field, we recommend you make the same entries as you did on the setup screen for box 800.
6. Repeat steps 2 through 5 to set up Routing box 801. In step 2, type **801** (instead of 800) to access box 801. In the **DESTINATION FOR DIGITS** field, you may decide to modify or simply not include the single-digit dialing options, since this box will control how calls are routed when the office is closed. If you choose to use the same single-digit dialing options, simply re-enter them here.
7. To save all setup entries and exit the Routing Box setup screen, **press <F10>**. The Box Information menu displays.

2.5.6.5 Setting Up Prototype Mailbox 9994

You need to create a mailbox for each subscriber who will use the system to record messages. Since most of the setup information will be the same for every mailbox you need, you should review the system's prototype mailbox, which is used as the mailbox setup model. The prototype mailbox is box number 9994. Every time you select to create a new mailbox, the system does so by making a copy of mailbox 9994.

1. From the Box Information menu, select **MAIL BOX**. The Mail Box setup screen displays with the Page Number menu.
2. **Press <F4>** to access the box selection screen. A small window displays prompting you for the box number. Type **9994** then press <Enter>.
3. Press <Enter> to move the cursor to the **TRANSFER TYPE** field. When a call is routed to the mailbox, the first action taken is to transfer the call to the number specified in the **TO:** field. The Lite system offers several options as to how the call can be transferred. When you move the cursor to this field, the various options are presented in a menu.

All transfer type options are described below. Use this information to select a transfer type. Note that in almost all system setups, you should select either the **Blind** or **Wait for Ring** transfer type, so the system can function most efficiently. The default setting is Wait for Ring.

NO TRANSFER

The Lite system does not transfer the call. Instead, it plays the mailbox owner's personal greeting (if one has been recorded) or a system default greeting. The caller then has several available options before recording a message.

BLIND

The Lite system transfers the call by dialing the number, then dropping out of the call. It transfers the call without monitoring to check whether the called party is busy, answers, etc. The final outcome of the call is the total responsibility of telephone system. If the telephone has transfer-recall capabilities, then if the telephone system transfer-recall timer expires, the call is returned to the Lite system. (The Lite system cannot perform call queuing when using Blind call transfers.)

WAIT FOR RING

This is a combination of the Wait For Answer and Blind transfer types. If the called party is busy, the calling party is offered the same options as with the Wait For Answer transfer type. If ringing is detected on the line, the Lite system executes a Blind transfer and drops out of the call. (The Lite system *can* perform call queuing if the extension is busy.)

WAIT FOR ANSWER

The Lite system dials the number and monitors the line. If the called party is busy, the Lite system offers the caller options to hold, leave a message, call another extension, etc. If the called party is not busy, the Lite system monitors the line, waiting for the called party to answer. If the called party does not answer within a specified number of rings, the Lite system abandons the transfer and plays the personal greeting, takes a message, etc. If the called party *does* answer, the Lite system announces the call "*I have a call for you, <mailbox owner's name>*" and completes the transfer. (The Lite system can perform call queuing if the extension is busy.)

SCREEN

This transfer type functions exactly the same way as with the Wait For Answer transfer type until the called party answers. Once the called party answers, the Lite system plays a system prompt offering the called party several options:

- Press 1 to accept the call. The parties are connected.

- Press 2 to have the system voice the mailbox owner's currently active greeting to the called party.
- Press 3 to send the calling party to the destination selected in the **IF CALLER CHOOSES OTHER OPTIONS** field on Page 2 of the mailbox's Mail Box setup screens.
- Press 4 plus a greeting number (0 through 9) to play the selected greeting to the caller, provided that the greeting has been recorded.
- Press 5 plus any valid box number to send the calling party to that box, where the call is treated as would any other call to that box.
- Press 6 to accept the call. The parties are connected, but the Lite system remains connected to the call and records the conversation. The recording is stored as a message in the called party's mailbox (provided the host telephone system allows conferencing on voice mail ports).

(With the Screen transfer type option, the Lite system can perform call queuing if the extension is busy.)

4. Press <Enter> to move the cursor to the **TO:** field, and confirm the letter **X** displays in this field. This entry instructs the Lite system to transfer calls to the extension number that matches the box number.
5. Press <Enter> to move the cursor to the **CURRENTLY ENABLED** field. Verify this field is set to **Yes**.
6. Press <Enter> to move the cursor to the **TRANSFER SCHEDULE** field. Verify this field is set to **Always**.
7. Press <Enter> to move the cursor to the **SEQUENCE TO TURN ON MESSAGE WAITING LAMP** field. The entries displayed in this field were set during program setup and should be sufficient. Review the settings shown, and make any changes you feel are necessary. For details, refer to the phone documentation and technical bulletin for the phone system.

Note: The letter **X** represents the box number, a comma (,) represents a pause, and an exclamation point (!) represents a hookflash. For example, if the Lite system needs to dial the extension number, then hookflash and dial 44 to turn on a message waiting lamp, this field should read: !,44

8. Press <Enter> to move the cursor to the **SEQUENCE TO TURN OFF MESSAGE WAITING LAMP** field. The entries displayed in this field were set during program setup and should be sufficient. Review the settings shown, and make any changes you feel are necessary. For details, refer to the phone documentation and technical bulletin for the phone system.
9. **Press <F9>** to move to page 2 of the Mail Box setup screen.
10. Press <Enter> to move the cursor to the **AFTER PLAYING GREETING** field. Verify this field is set to **Wait For A Digit**.
11. To save the prototype mailbox setup you specified and exit the setup screens, **press <F10>**. The program displays the Box Information menu.

2.5.6.6 Creating Subscriber Mailboxes

Once you set up Prototype mailbox 9994, you can now efficiently set up all the mailboxes that will be used by subscribers on the system.

1. From the Box Information menu, select **MAIL BOX**. The Mail Box setup screen displays.
2. To add a new mailbox, **press <F2>**.
3. A small window displays prompting you for the box number. Enter the **number of the first mailbox** you want to create, then press <Enter>.

Note: Enter as the mailbox number the same number as the extension to which the mailbox will transfer calls. Also, note that the default password for each mailbox is the same as the box number.

4. The Lite system creates the new mailbox by making a copy of the Prototype mailbox. The new mailbox is displayed on the screen.

5. Repeat steps 3 through 5 for each subscriber mailbox you want to create.
6. Once you create all necessary mailboxes, continue with the next procedure, below.

2.5.6.7 Customizing Subscriber Mailboxes

Using information the system supervisor provides on the Mailbox Setup Worksheets, you can now customize the mailboxes you created for each subscriber on the system.

The procedure below identifies the fields you should be sure to customize for each mailbox. Fields that are not specifically discussed contain default values that should be appropriate in nearly all setup situations. Therefore, it is unlikely that you need to modify these fields. Detailed information on completing all fields on Mail Box setup screens is provided in the *Installation and Maintenance Manual*. You can also access online help on any screen by pressing <F1>.

1. To access the mailbox you want to customize, **press <F4>**. A small window displays prompting you for the box number. Type **the box number** then press <Enter>. The Mail Box Page 1 setup screen displays.
2. Press <Enter> to move the cursor to the **FIRST NAME** field. Enter the mailbox owner's first name. Press <Enter> to move the cursor to the **LAST** field. Enter the mailbox owner's last name.
3. To go to Page 2 of the Mail Box setup screen, **press <F9>**. The Page 2 screen displays.

M A I L B O X Page 1

Box number: **10** FIRST NAME: **Sample** Last: **Mail box**

<p style="text-align: center;">CALL TRANSFER INFORMATION</p> <p>Transfer type: [REDACTED] To: X [REDACTED] Rings to answer: 4 Use 3-way calling? No Get caller's name? No Record conversation? No Currently enabled? Yes Transfer schedule: Always</p>	<p style="text-align: center;">PERSONAL DATA</p> <p>Password: 10 Name recorded: No Greeting recorded: No</p> <p style="text-align: center;">PRIVILEGES</p> <p>Class of service: 0 Restricted - Client of: [REDACTED]</p>
--	--

Sequence to turn ON message-waiting lamp: [REDACTED]	New: 0
Sequence to turn OFF message-waiting lamp: [REDACTED]	Old: 0

M A I L B O X (Page 2)

Box number: **10** First Name: **[REDACTED]** Last: **[REDACTED]**

PAGER NUMBER: **[REDACTED]** Pager type: **Digital**
 Times to call: **1** Mins between calls: **0** Schedule: **Always** Enabled? **No**

After playing greeting: **[REDACTED]**
 If caller chooses "other options": Go to box ... - box **821**
 After leaving message, Go to box ... - box **821**
 If call is via D.I.D. play greeting in language: **1**
 Auto-forward NEW msgs to box **[REDACTED]** after **0** hours. Schedule: **always**

MESSAGE DELIVERY -	Where and When	Repeat	Interval	Schedule
Call:	[REDACTED]	2	60	Schedule A
Call:	[REDACTED]	3	10	Schedule B
Call:	[REDACTED]	3	10	Schedule C
Call:	[REDACTED]	3	10	Always
Call:	[REDACTED]	3	10	Always

Run this cycle **1** times. Currently enabled? **Disabled**

F1=Help F2=Add F3=Delete F4=Select F5=Prev F6=Next F9=Next page F10=Exit

4. Press <Enter> to move the cursor to the **PAGER NUMBER** field. If the subscriber is to use the Paging feature, use the following information to complete this section of the Mail Box setup screen.

PAGER NUMBER

Enter the telephone number of the paging service. The mailbox owner may change the number remotely. Normally, access codes for outside lines are not required here. Instead, that information should be entered on the System Information / General setup screen.

To restrict pager calls to use lines in a particular line group, enter the letter (A, B, C, or D) of the line group in braces { } before the telephone number (for example, {A}5551212).

Tone or Voice pagers may be used with the Message Delivery feature discussed later in this section.

The pager number you enter can contain the digits 0 through 9, star (*), pound (#), and the following special characters:

Character	Use
P	Use pulse (also known as 'rotary') dialing.
T	Use tone dialing (the default).
,	Short pause (duration can be changed in Technical Information screen. Default is one second).
%	Medium pause (equal in length to 4 commas).
L	Long pause (equal in length to 8 commas).
!	Hookflash.
N	No progress tones (must be last character). The Lite system ignores all call progress tones during the course of the call. When it has finished dialing, the system immediately assumes that the pager system has answered.
[]	Enclosing the number in brackets prevents the mailbox owner from being able to call in and change the number.
{ }	Specifies a line group is to be used (for example, {A}555-1212

Character	Use
	indicates "choose any line in line group A, and dial the number 555-1212").
any other character	Can be used for punctuation and is ignored.

PAGER TYPE

The Lite system supports both Tone and Digital pagers in this section of the mailbox programming. Specify here which type of pager the mailbox owner has (Digital, Tone or None).

When a caller asks the Lite system to page a mailbox owner, the Lite system looks for a free line on which to call the paging service. If no lines are free to make the call, the Lite system queues the request and re-tries every 10 seconds for approximately 10 minutes.

NUMBER OF TIMES TO CALL

The Lite system calls the pager the number of times you specify in this field. Repetitive paging may be useful if the pager is turned off periodically or is out of pager range.

Note: This field is used to tell the Lite system how many successful calls it should make to the paging service. Do not confuse this with the pager-retry feature. If the Lite system calls the pager number and does not hear it ring and answer, then it automatically re-tries the call at 10-second intervals, for a pre-defined number of times.

MINUTES BETWEEN CALLS

If you enter a number greater than 1 in the **TIMES TO CALL** field, this field instructs the Lite system how long it should wait between re-calls.

Note: This field tells the Lite system how long to wait between successful calls to the paging service. Do not confuse this with the pager-retry feature.

CALL SCHEDULE

The Pager notification feature follows a time schedule. The options are:

Schedule	Result
ALWAYS	Pager notification is available at all times.
DAY SERVICE	Pager notification is available only during day/lunch service, as defined in the System Information / Business Hours screen.
NIGHT SERVICE	Pager notification is available only during non-day/lunch service, as defined in the System Information / Business Hours screen.
SCHEDULE A, B, C, or D	Pager notification is available only during the schedule defined on Page 3 of the Mail Box setup screen for this mailbox.

ENABLED

Set this field to **Yes** to indicate that the pager feature for this mailbox is currently on. Set the field to **No** to indicate that the pager feature is off. The mailbox owner can also toggle this field on and off by calling into the system. If this field is set to **No**, it overrides the call schedule set in the previous field.

- Press <Enter> to move the cursor to the first **MESSAGE DELIVERY** field. If the subscriber is to use the Message Delivery feature, use the following information to complete this section of the Mail Box setup screen.

CALL

Enter the telephone number the Lite system should call to inform the mailbox owner that there are new messages in his/her mailbox.

The number can contain the DTMF digits 0 - 9, * and #, plus any of the following special characters:

Character	Use
P	Use pulse (also known as 'rotary') dialing.
T	Use tone dialing (the default).
,	Short pause (duration can be changed in Technical Information screen. Default is 1 second).

Character	Use
%	Medium pause (equal in length to 4 commas).
L	Long pause (equal in length to 8 commas).
!	Hookflash.
[]	Enclosing the number in brackets prevents the mailbox owner from being able to call in and change the number.
{ }	Specifies a line group is to be used (for example, {A}555-1212 indicates “choose any line in line group A, and dial the number 555-1212”).
H	Hang up immediately after dialing the number (must be last character).
M	Answering machine. This must be the last character in the telephone number. It tells the Lite system that the number being called has an answering machine attached. When the Lite system calls the number, it announces that there are messages, as usual. If the Lite system has not received a DTMF digit (1 for Yes, anything else for No), by the end of the announcement cycle(s), it assumes that it is talking to an answering machine, and proceeds to play each new message in turn.
V	Voice pager. This must be the last character in the telephone number. Details of voice pager programming are found later in this section.
I	Internal (must be the first character). Overrides the INTERNAL parameter (in the configuration file VM.CFG) and treats this number as an internal call regardless of the number of digits. The Lite system does not dial the sequence specified in the General Information / Digits To Get A Line On External Call field.
E	External (must be the first character). Overrides the INTERNAL parameter (in the configuration file VM.CFG) and treats this number as an external call regardless of the number of digits. The Lite system dials the sequence specified in the General Information / Digits To Get A Line On External Call field.
N	No progress tones (must be the last character). The Lite system ignores all call progress tones during the course of the call.
any other character	Can be used for punctuation and is ignored.

The owner of a mailbox can call in and remotely change the first Message Notification number, but cannot use or modify special characters.

REPEAT

Enter the number of successful calls to each telephone number. A successful call is generally defined as one where the Lite system has seized an available line port, dialed the number, and detected an answer. If the call is not successful (for example, the called number was busy) the Lite system automatically re-tries every few seconds up to twenty times.

INTERVAL

If the Repeat field contains a number greater than 1 or there are additional Call number sequences, enter the interval (in minutes) between calls to this number and/or the interval before proceeding to the next Call number sequence.

SCHEDULE

Select when the Lite system should call this number. The options are:

Schedule	Result
ALWAYS	The number is called any time a new message is left in the mailbox.
DAY SERVICE	The number is called only during day/lunch service, as defined in the System Information / Business Hours screen.
NIGHT SERVICE	The number is called only during non-day/lunch service, as defined in the System Information / Business Hours screen.
SCHEDULE A, B, C, or D	The number is called only during the schedule defined on Page 3 of the Mail Box setup screen for this mailbox.

RUN THIS SEQUENCE N TIMES

Once the Lite system has called every number listed, it considers that it has run the sequence one time. It will then check the value in this field. If this field is set to a number higher than 1, the Lite system starts again and repeats the sequence the specified number of times.

CURRENTLY ENABLED?

This field identifies which messages the Lite system is to deliver:

DISABLED	The Lite system does not deliver messages.
URGENT MSGS ONLY	The Lite system delivers only messages marked urgent, but does not call to deliver non-urgent messages.
ALL MESSAGES	The Lite system calls every time a message is deposited into the mailbox.

Setting this field to **DISABLED** overrides the **SCHEDULE** field.

The owner of a mailbox can call in remotely and turn his/her Message Delivery feature on or off, or change the first number to be called. The other telephone numbers, if in use, cannot be changed remotely.

6. To go to Page 3 of the Mail Box setup screen, **press <F9>**. The Page 3 screen displays.

M A I L B O X Page 3					
Box number:10		First Name:Sample		Last:Mail box	
SCHEDULE A		Start	End	SCHEDULE B	
SUN:	0:00	0:00	Sun:	0:00	0:00
Mon:	0:00	0:00	Mon:	0:00	0:00
Tue:	0:00	0:00	Tue:	0:00	0:00
Wed:	0:00	0:00	Wed:	0:00	0:00
Thu:	0:00	0:00	Thu:	0:00	0:00
Fri:	0:00	0:00	Fri:	0:00	0:00
Sat:	0:00	0:00	Sat:	0:00	0:00
SCHEDULE C		Start	End	SCHEDULE D	
Sun:	0:00	0:00	Sun:	0:00	0:00
Mon:	0:00	0:00	Mon:	0:00	0:00
Tue:	0:00	0:00	Tue:	0:00	0:00
Wed:	0:00	0:00	Wed:	0:00	0:00
Thu:	0:00	0:00	Thu:	0:00	0:00
Fri:	0:00	0:00	Fri:	0:00	0:00
Sat:	0:00	0:00	Sat:	0:00	0:00
F1=Help F2=Add F3=Delete F4=Select F5=Prev F6=Next F9=Next page F10=Exit					

7. Press <Enter> to move the cursor to the first **SCHEDULE A** field. If the subscriber is to use the Pager or Message Delivery feature according to a particular schedule, use the following information to complete the Mail Box Page 3 setup screen.

START

Enter the time at which this schedule should begin on this day. The time should be entered in 24-hour format (for example, enter 20:00 for 8:00 PM).

END

Enter the time at which this schedule should end on this day. The time should be entered in 24-hour format (for example, enter 20:00 for 8:00 PM).

Note: If you want the schedule to be active all day, enter 00:00 as the **START** time and 24:00 as the **END** time.

3. To go to Page 4 of the Mail Box setup screen, **press <F9>**. The Page 4 screen displays.

M A I L B O X (Page 4)			
Box number:	10	First Name:	[REDACTED]
		Last:	[REDACTED]
Hotel guest privileges only? No			
WAKE-UP TIME:	7:00	Currently scheduled?	No
PERSONAL DISTRIBUTION LISTS			
Name:	[REDACTED]	Name:	[REDACTED]
Enabled?	Yes	Enabled?	Yes
Members:	[REDACTED]	Members:	[REDACTED]
Name:	[REDACTED]	Name:	[REDACTED]
Enabled?	Yes	Enabled?	Yes
Members:	[REDACTED]	Members:	[REDACTED]
Name:	[REDACTED]	Name:	[REDACTED]
Enabled?	Yes	Enabled?	Yes
Members:	[REDACTED]	Members:	[REDACTED]
F1=Help F2=Add F3=Delete F4=Select F5=Prev F6=Next F9=Next page F10=Exit			

4. Confirm that the **ENABLED** field is set to **Yes** for all four personal distribution lists. This allows subscribers to create up to 4 personal distribution lists in their mailboxes, which they can then use when sending messages to groups of subscribers.
5. Repeat steps 1 through 9 to customize each mailbox you created for each subscriber on the system. Once you customize all subscriber mailboxes, continue with the next procedure.

2.5.6.8 Customizing the System Supervisor Mailbox

1. To access the system supervisor mailbox, **press <F4>**. A small window displays prompting you for the box number. Type **70** then press **<Enter>**.
2. Press **<Enter>** to move the cursor to the **FIRST NAME** field. Type **SUPERVISOR** in this field. Press **<Enter>** to move the cursor to the **LAST** field. Enter the **system supervisor's last name**. Note that though you may type any name or words in these fields, using these entries identifies this mailbox as the supervisor mailbox and identifies the individual who is currently acting as the on-site system supervisor.
3. Press **<Enter>** to move the cursor to the **CLASS OF SERVICE** field. Verify that **7** is entered in this field. This entry assigns class of service 7, which has supervisor privileges, to this mailbox.
4. To go to Page 2 of the Mail Box setup screen, **press <F9>**. The Page 2 screen displays.
5. To complete the supervisor mailbox setup, repeat steps 4 through 9 of the previous procedure.
6. To save all mailbox customizations and exit the Mail Box setup screen, **press <F10>**. The Box Information menu displays.

2.5.6.9 Recording Routing Box Greetings

As described in **section 2.5.6.2**, the following procedure guides you through recording two greetings in both Routing boxes 800 and 801: an office open greeting and a holiday greeting in box 800, and an office closed greeting and a holiday greeting in box 801. Sample greetings for these boxes and for box 821 are provided in **section 3.2.1**.

Note: When you record Routing box greetings, you must include instructions that identify any single-digit call routing options available to the caller.

1. From a telephone, call into voice mail and log into **supervisor mailbox 70**. Note that the default password for the mailbox is the same as the mailbox number, 70.
2. The Lite system tutorial session starts. Complete the tutorial. When prompted to record the name and greeting, you may elect to identify this as the supervisor mailbox. When changing the password, be sure to inform the system supervisor of the number you select. When you complete the tutorial, press <*> to prevent it from voicing the next time the box is accessed.
3. The system voices the Main menu:

“To listen to your messages press 1. To send a message press 2. To change your options press 3.”

Press 3 to change options. The system voices the Options menu:

Options Menu	
To Record Your Name	Press 1
To Record Your Greeting	Press 2
To Change Your Password	Press 3
To Change Your Call-Transfer Feature	Press 4
To Change Your Message Notification Feature	Press 5
To Change Your Pager Feature	Press 6
To Review Msgs Scheduled for Future Delivery	Press 7
To Change Your Personal Distribution Lists	Press 8
To Retrieve a Message Previously Sent	Press *
To Return to the Main Menu	Press #

4. From the Options menu, **press 2**.
5. When prompted, **press 800** to indicate you want to work with Routing box 800.

6. When prompted, **press 1** to confirm the number you entered or press # if the number you entered was incorrect. Once you press 1 to confirm, the system voices the following options:

To Replay the Greeting	Press 1
To Re-Record the Greeting	Press 2
To Delete the Greeting	Press 3
To Choose a New Greeting	Press 5
To Exit	Press #

7. To record the first greeting for the Routing box, **press 2**. The system prompts you to enter the number of the greeting you want to record. Enter **greeting number 0**. Then, follow the prompts to **record the office open greeting**.
8. To record the holiday greeting for Routing box 800, repeat step 7, select **greeting number 1**, and **record the holiday greeting**.
9. To record greeting(s) for Routing box 801, **press <#>** to exit the menu shown above and return to the Options menu. Then repeat steps 4 through 7 above. In step 5, **press 801** to indicate you want to work with Routing box 801. In step 7, **record the office closed greeting**, instead of the office open greeting.
10. To record the holiday greeting for Routing box 801, repeat step 7, select **greeting number 1**, and **record the holiday greeting**.
11. To record the greeting for Routing box 821, **press <#>** to exit the menu shown above and return to the Options menu. Then repeat steps 4 through 7 above. In step 5, **press 821** to indicate you want to work with Routing box 821. In step 7, **record the office open greeting** call routing options, **omitting the introductory remarks** “Welcome to ...”
12. When you have recorded all necessary greetings, **press <#>** to return to the Options menu, then press <#> to return to the Main menu.

Be sure to instruct the system supervisor to refer to **section 3.2** for detailed instructions on changing the active Routing box greetings and recording new greetings.

2.6 Default Database Structure Overview

As mentioned previously, the Lite system contains a default database with a setup configuration that allows the Lite system to efficiently perform fundamental call processing tasks with minimal system adjustments by the installing technician. Information in this section highlights portions of this default database configuration. More detailed information on the purpose of Routing boxes and mailboxes and how box settings and other default settings affect system functionality is provided earlier in this document.

Note: Though you may make adjustments to specific information relating to this default setup, **you are urged to maintain the general configuration of Routing boxes 800, 801, and 821, class of service 7, and supervisor mailbox 70.** This configuration allows the Lite system to efficiently perform fundamental call processing tasks. Maintaining it helps both you, the technician, and the Lite system technical support to efficiently service the system and resolve any call processing issues.

- **Technician Password:**
 - * 1234

- **Business Hours** (specified on System Information / Business Hours screen):
 - * 8:00 AM - 5:00 PM

- **Routing Box 800:**
 - * Answers all incoming calls during day/lunch hours (specified on System Information / Business Hours screen)
 - * Owned by mailbox 70

- **Routing Box 801:**
 - * Answers all incoming calls during non-day/lunch hours (specified on System Information / Business Hours screen)
 - * Owned by mailbox 70

- **Routing Box 821:**
 - * Routes calls that have already passed through Routing box 800 or 801
 - * Owned by mailbox 70

- **Class of Service 0:**

- * Set up with the following parameter settings (for information on specific parameter fields, refer to **section 2.5.5.8**):

MAXIMUM NUMBER OF GREETINGS: **10**
MAXIMUM NUMBER OF MESSAGES: **200**
MAXIMUM GREETING LENGTH (SECS): **60**
MAXIMUM MESSAGE LENGTH (SECS) **60**
AUTO-DELETE OLD MESSAGES AFTER **30** DAYS.
AUTO DELETE NEW MESSAGES AFTER **99** DAYS.
SUPERVISOR STATUS? **No**
ACCESS TO GROUP-BOXES? **Yes**
DIAL-OUT ALLOWED? **No**
ACCESS TO P.A.? **Yes**
PLAY MENU AFTER GREETING? **No**
ALLOWED TO RECEIVE FAXMAIL? **No**
OPERATOR BOX (DAY): **888** (NIGHT): **888**
WHEN EXITING OPEN MAILBOX, GO TO BOX: **821**
MAX LINES ALLOWED TO HOLD FOR ONE BOX: **2**
WHILE IN QUEUE, SAY POSITION IN LINE? **No**
TRY EXTENSION **3** TIMES BEFORE GOING BACK TO CALLER
RESTRICTED DIGITS: [**None**]

- **Class of Service 7:**

- * Set up with the class of service 0 options, but with SUPERVISOR STATUS? **enabled**.

- **Extension Length:**

- * 3 digits

- **Password Length:**

- * 4 digits

- **Default Passwords :**

- * Equal the mailbox numbers

- **Mailbox 70:**

- * Set up as the Supervisor mailbox with CLASS OF SERVICE: 7

- **Prototype mailbox 9994** (features automatically assigned to all mailboxes created):

TRANSFER TYPE: **Wait for Ring**

CLASS OF SERVICE: **0**

To: **X** (*signifies the mailbox number*)

CURRENTLY ENABLED: **Yes**

TRANSFER SCHEDULE: **Always**

PASSWORD: **X** (*signifies the mailbox number*)

SEQUENCE TO TURN ON/OFF MESSAGE WAITING LAMP: (*set by Integration program*)

AFTER PLAYING GREETING: **Wait for digit**

2.7 Setting Up the System Using the Teleparameter Feature

This section provides instructions on using the teleparameter feature to set up a new system at a customer site or to later make modifications to the system. Using the teleparameter feature, you can change the parameter values that affect system-wide setup information, box setups, and VM.CFG file data by simply calling into the system. You simply log into supervisor mailbox 70 over the telephone, select to modify system parameters, then, as prompted, enter codes that identify each parameter you want to change and the new value to which you want to set the parameter. The screen illustrations and parameter value table provided in this section indicate the parameters and their associated codes.

Technicians who have experience setting up Corporate Office, VVP, Small Office, or the Lite systems may prefer to use the Teleparameter feature to quickly make modifications and get the Lite system up and running at the customer's site. Be advised, however, that since this technique involves inputting codes that represent system parameters and corresponding values to which parameters are to be set, it is a bit more difficult to use effectively if you are unfamiliar with setting up Corporate Office, VVP, Small Office, or Lite systems. For this reason, we recommend that technicians unfamiliar with Corporate Office, VVP, Small Office, or Lite systems attach a laptop to the PC and use the instructions provided in the previous sections to complete all necessary system setup steps.

<p>Note: If you choose to set up the system using the Teleparameter feature, be sure to first review section 2.5.6.2 and section 2.6 so you clearly understand the setup of the default database included on the Lite system unit.</p>

2.7.1 Using the Teleparameter Feature to Set up a New System

2.7.1.1 Running the First Time Setup Utility

The Lite system voice processing software is pre-installed on the Lite system unit before it is shipped to you. You must, however, run the First Time Setup utility so you can configure certain installation parameters for each specific customer's site. Use the following procedure to run this utility by calling into the system over the telephone:

1. From a telephone, call into voice mail and log into **supervisor mailbox 70**. Note that the default password for the mailbox is the same as the mailbox number, 70.
2. The Lite system tutorial session starts. Complete the tutorial. When prompted to record the name and greeting, you may elect to identify this as the supervisor mailbox. When changing the password, be sure to inform the system supervisor of the number you select. When you complete the tutorial, press <*> to prevent it from voicing the next time the box is accessed.
3. The system voices the Main menu:

“To listen to your messages press 1. To send a message press 2. To change your options press 3.”

4. To access the Supervisor menu, **press 6** (this option is not voiced). The system voices the Supervisor menu options:

Supervisor Menu	
For Mailbox Administration	Press 1
For Routing Box Administration	Press 2
For Question Box Administration	Press 3
For Port Administration	Press 4
To Change the System Broadcast Message	Press 5
To Change the Voice Mail Day / Night Service	Press 6
To Change the System Time	Press 7
To Change the System Date	Press 8
To Modify System Parameters	Press 9
To Perform First-Time Setup	Press 0

5. From the Supervisors menu, **press 0** to perform first time setup. The system prompts you to enter the **Technician password**. By default, this password is **1234**.
6. Follow the prompts and enter the requested information. When you are prompted to indicate the type of phone system with which you are working, make your selection from the appropriate table below. The first table lists the phone systems supported with the Small Office Lite. Note that the * indicates phone systems that will integrate, but are not a likely solution due to the capacity of the Small Office Lite in relation to the size of the phone system—hence, a larger VP system is recommended. The second table lists the phone systems supported with the Debut unit.

Small Office Lite System Integrations

#	Phone System	#	Phone System
56	Atlas 50	20	Iwatsu ZT-D
29	Atlas 200	1	List of Technical Bulletins Available
08	Comdial DSU/DSUII	94	Lucent Definity G3 – Calista Box – Vectoring – Bridged Mode
11	Comdial DXP, DXP Plus	102	Lucent Definity G3 – Inband – No VoiceBridge*

#	Phone System	#	Phone System
74	Comdial FX	92	Lucent Definity G3 – VoiceBridge *
22	Comdial Executech 2000	93	Lucent Definity G3 – VoiceBridge – Vectoring – Bridged Mode *
44	Comdial Unisyn	106	Lucent Definity Pro Logic
45	Encore CX - ECX 1832 / 3672 / 36112	13	Lucent Merlin II
77	Ericsson MD-110	34	Lucent Merlin Legend
75	Fujitsu 9600 with Serial Integration*	97	Lucent Partner ACS
96	Fujitsu Allegra 26	50	Lucent Partner II
78	Fujitsu Series 3 / Starlog	105	Lucent Partner Endeavor
41	Fujitsu Starlog	38	Lucent Partner Plus
80	Harris 20/00	37	Lucent System 25
07	Harris Intellicom 500	63	Lucent System 75 – Voice Bridge *
06	Harris Intellicom 2000	91	Lucent System 85 and Definity Generic 2 – VoiceBridge *
107	Hitachi HCX5000*	31	Mitel COV with D/42D-SX Voice Boards
32	Intertel GX152D	39	Mitel SX100 Digital PABX with ONS Integration
55	Isoetec IDS 108 / 228	84	Mitel SX200 Light with COV Integration
49	Isoetec System 96	89	Mitel SX200 Light with DNIC Integration
79	ITT/ Cortelco Aries	85	Mitel SX200 Light with ONS Integration
30	ITT / Cortelco System 3100* (Rhetorex only)	83	Mitel SX200D with ONS Integration
67	ITT ECS 4.02P	86	Mitel SX2000 and SX2000 Light with COV Integration
69	ITT ECS 6.3	88	Mitel SX2000 and SX2000 Light with DNIC Integration
28	Iwatsu ADIX	81	Mitel SX50 with COV Integration
90	Mitel SX50 with DNIC Integration	10	Samsung Prostar 56EX / 120MX / 1224
17	NEC Electra Professional Level I	42	Samsung DCS – Digital
54	NEC Electra Professional Level II	9	Siemens Hicom 150E
21	NEC Mark II	12	Siemens Saturn I, II, III
51	NEC NEAX-1400 IMS	15	SMDI Installation Guide/Centrex*

#	Phone System	#	Phone System
73	NEC NEAX-2000	40	Southwestern Bell Landmark DKS 308 / 616
35	NEC NEAX-2400 Serial Integration	19	Sprint Protégé / Macrotel MT360 / 824 KSU
33	Nitsuko DSO-1 / ONYX	65	SRX
113	Nitsuko 124I	59	Tadiran Coral I, II, & III
114	Nitsuko 384I	99	Tadiran Coral I, II, & III E&M Inband with Voice Pro
115	Nitsuko DS2000	100	Tadiran Coral I, II, & III with SMDI
103	Northern Telecom meridian – Calista Box- Vectoring – Bridged Mode *	98	Tadiran Coral 9.87
72	Northern Telecom Norstar D42NS	68	Telrad 2464
27	Northern Telecom Norstar - with VMI Adapters	64	Telrad Digital Key BX, 200 Digital
53	Northern Telecom SL-1 and Meridian-1/SL-1, (with D42-SL) *	46	Toshiba DK-16 / 24 / 56 / 96
18	Panasonic 1232 – Analog	16	Toshiba DK-280 & 40
24	Panasonic DBS	26	Toshiba Perception E
36	Panasonic KXT-336	95	Toshiba Perception EX
23	Panasonic KX-TD 1232 Digital	57	Toshiba Perception I & II
66	Panther II 820 / 1032 / 2064 Release IV	60	Toshiba Strata E
52	Philips SOPHO-S	87	Vodavi DHS
32	Premier ESP / Intertel GMX	43	Vodavi Infinite DVX1, DVX2, & DVX3
25	Programming Initial Day, Night, & Lunch Routing Boxes using Trunk I.D. Codes	48	Vodavi Starplus 2448EX / 4896EX
47	Redwood 3.2	58	Vodavi Starplus 96EX
101	Rolm 8000 Series CBX – Voice Bridge*	14	Vodavi Starplus Digital
108	Rolm 9000/9751 Series SBX – Voice Bridge*	116	Vodavi Starplus Triad-S
70	Rolm 9200 BCS / Siemens HCM 200	62	Win 100D

#	Phone System	#	Phone System
109	RoIm 9751/Release 9006I - Inband		

Debut System Integrations

#	Phone System	#	Phone System
56	Atlas 50	113	Nitsuko 124I
29	Atlas 200	114	Nitsuko 384I
08	Comdial DSU/DSUII	115	Nitsuko DS2000
11	Comdial DXP, DXP Plus	27	Northern Telecom Norstar - with VMI Adapters
74	Comdial FX	18	Panasonic 1232 - Analog
22	Comdial Executech 2000	24	Panasonic DBS
44	Comdial Unisyn	36	Panasonic KXT-336
79	Cortelco Aries	23	Panasonic KX-TD 1232 Digital
45	Encore CX - ECX 1832 / 3672 / 36112	32	Premier ESP / Intertel GMX
96	Fujitsu Allegra 26	25	Programming Initial Day, Night, & Lunch Routing Boxes using Trunk I.D. Codes
78	Fujitsu Series 3 / Starlog	47	Redwood 3.2
41	Fujitsu Starlog	10	Samsung Prostar 56EX / 120MX / 1224
80	Harris 20/20	42	Samsung Prostar DCS - Digital
07	Harris Intellicom 500	9	Siemens Hicom 150E
71	Intertel GX152D	12	Siemens Saturn I, II, III
55	Isoetec IDS 108 / 228	40	Southwestern Bell Landmark DKS 308 / 616
49	Isoetec System 96	19	Sprint Protégé / Macrotel MT360 / 824 KSU
28	Iwatsu ADIX	98	Tadiran Coral 9.87
20	Iwatsu ZT-D	68	Telrad 2464
1	List of Technical Bulletins Available	46	Toshiba DK-16 / 24 / 56 / 96
34	Lucent Merlin Legend	16	Toshiba DK-280
97	Lucent Partner ACS	26	Toshiba Perception E

#	Phone System	#	Phone System
105	Lucent Partner Endeavor	95	Toshiba Perception EX
50	Lucent Partner II	57	Toshiba Perception I & II
38	Lucent Partner Plus	87	Vodavi DHS
37	Lucent System 25	43	Vodavi Infinite DVX1, DVX2, & DVX3
85	Mitel SX200 (Lightware 1004+) Light with ONS Integration	48	Vodavi Starplus 2448EX / 4896EX
17	NEC Electra Professional Level I	58	Vodavi Starplus 96EX
54	NEC Electra Professional Level II	14	Vodavi Starplus Digital
21	NEC Mark II	116	Vodavi Starplus Triad-S
51	NEC NEAX-1400 IMS	62	Win 100D
33	Nitsuko DSO-1 / ONYX		

- Once you enter all necessary information, **press 1** as prompted to reboot the PC. You must allow the system to reboot so it can reset several parameters based on the information you entered. When the system reboots, your call into it is disconnected. Continue with the next procedure.

2.7.1.2 Adjusting System Information

You may need to customize certain fields on the System Information screens. Use the following procedure:

- From a telephone, call into voice mail and log into the **supervisor mailbox 70**. The system voices the Main menu:

“To listen to your messages press 1. To send a message press 2. To change your options press 3.”

- To access the Supervisor menu, **press 6** (this option is not voiced). The system voices the Supervisor menu options:

Supervisor Menu	
For Mailbox Administration	Press 1
For Routing Box Administration	Press 2
For Question Box Administration	Press 3
For Port Administration	Press 4
To Change the System Broadcast Message	Press 5
To Change the voice mail Day / Night Service	Press 6
To Change the System Time	Press 7
To Change the System Date	Press 8
To Modify System Parameters	Press 9
To Perform First-Time Setup	Press 0
To Exit	Press #

- From the Supervisors menu, **press 9** to modify system parameters. The system prompts you to enter the **Technician password**. By default, this password is **1234**.
- At the prompt, enter the number of the parameter you want to change, then, as prompted, the value to which you want to change the parameter. Parameter information is provided in a comprehensive table shown in **section 2.7.2**.

When you complete all modifications, **press #** to return to the Supervisor's menu.

<p>Note: Refer to section 2.7.2 for information on values you can specify for certain parameters and for information on adjusting parameters in the VM.CFG file. For detailed information on each field of System Information screens, refer to the <i>Installation and Maintenance Manual</i>.</p>

2.7.1.3 Adjusting Routing Box Information

As indicated in **section 2.5.6.2**, you need to adjust Routing Boxes 800, 801, and 821 to include any single-digit call routing options you want to provide to callers. You must also

record the necessary greetings for these boxes. Sample Routing box greetings are provided in **section 3.2.1**.

To record Routing box greetings, follow the procedure provided in **section 3.2.2**.

To modify single-digit call routing, you can follow the procedure in **section 3.2.3** or you can use the Teleparameter feature. To use the Teleparameter feature, follow steps 1 through 4 in the previous procedure, referring to the parameter numbers provided in **section 2.7.2**. For detailed information on each field of this screen, refer to the *Installation and Maintenance Manual*.

Note: If you enter a parameter number for a parameter that affects a particular box, the system prompts you to enter the **Item number**. The Item number identifies the particular box in which you want to change the parameter. At the Item number prompt, enter the **number of the box**.

Note: Refer to **section 2.7.2** for information on values you can specify for certain parameters and for information on adjusting parameters in the VM.CFG file. For detailed information on each field of Routing Box screens, refer to the *Installation and Maintenance Manual*.

2.7.1.4 Creating and Adjusting Mailbox Box Information

To create mailboxes on the system, follow the procedure in **section 3.1.1**. Once you create mailboxes, you can make detailed modifications to the box setups using the Teleparameter feature. To use the Teleparameter feature to adjust mailbox information in boxes you have created on the system, follow steps 1 through 4 in the procedure in **section 2.7.1.2**. For specific parameters you can adjust, refer to **section 2.7.2**. For detailed information on each field of these screens, refer to the *Installation and Maintenance Manual*.

Note: If you enter a parameter number for a parameter that affects a particular box, the system prompts you to enter the **Item number**. The Item number identifies the particular box in which you want to change the parameter. At the Item number prompt, enter the **number of the box**.

Note: Refer to **section 2.7.2** for information on values you can specify for certain parameters and for information on adjusting parameters in the VM.CFG file. For detailed information on each field of Box Setup screens, refer to the *Installation and Maintenance Manual*.

2.7.1.5 Creating Other Box Types and Adjusting Information

To create other types of boxes, you must first follow the procedures presented earlier in this document to connect a laptop computer to the Lite system unit and access Box Information setup screens. Once you create the boxes using this technique, you can make detailed modifications to the box setups using the Teleparameter feature. To use the Teleparameter feature to adjust information in boxes already created on the system, follow steps 1 through 4 in the procedure in **section 2.7.1.2**. For specific parameters you can adjust, refer to **section 2.7.2**. For detailed information on each field of these screens, refer to the *Installation and Maintenance Manual*.

Note: If you enter a parameter number for a parameter that affects a particular box, the system prompts you to enter the **Item number**. The Item number identifies the particular box in which you want to change the parameter. At the Item number prompt, enter the **number of the box**.

Note: Refer to **section 2.7.2** for information on values you can specify for certain parameters and for information on adjusting parameters in the VM.CFG file. For detailed information on each field of Box Setup screens, refer to the *Installation and Maintenance Manual*.

2.7.2 Teleparameter Value Tables

The following table identifies all parameters you can adjust using the teleparameter feature and the entries you can make to indicate specific values for each parameter. Refer to information after this table for additional entries you can make in some fields.

Task	Param. Number	Description	Acceptable Values	Notes:
Account Number Box Setup	2700	Minimum number of digits required for valid entry determination	1 - 9	A prompt for the Item number refers to the box number. Enter the box number.
Account Number Box Setup	2701	Maximum number of digits required for valid entry determination	1 - 30	A prompt for the Item number refers to the box number. Enter the box number.
Account Number Box Setup	2702	Number of seconds to wait before determining all digits are entered	0 - 9	A prompt for the Item number refers to the box number. Enter the box number.
Account Number Box Setup	2703	Action to take after maximum retry attempts if invalid account number is entered	0 = Return 1 = Say 'Goodbye' 2 = Go to another box 3 = Hang up	A prompt for the Item number refers to the box number. Enter the box number.
Account Number Box Setup	2704	Box associated with parameter 2703	(Valid mailbox number)	A prompt for the Item number refers to the box number. Enter the box number.
Account Number Box Setup	2705	Retry attempts to allow if invalid account number entered	0 - 9	A prompt for the Item number refers to the box number. Enter the box number.
Account Number Box Setup	2706	Number of mailbox that owns the Account Number box	(Valid mailbox number)	A prompt for the Item number refers to the box number. Enter the box number.
Account Number Box Setup	2707	Action to take if account number was previously collected during call	0 = Use the existing account number 1 = Ask for a new account number	A prompt for the Item number refers to the box number. Enter the box number.
Account Number Box Setup	2708	Repeat number entered for confirmation?	1 = Yes 0 = No	A prompt for the Item number refers to the box number. Enter the box number.

Task	Param. Number	Description	Acceptable Values	Notes:
Account Number Box Setup	2001	Action to take if valid account number is entered	0 = Return 1 = Say 'Goodbye' 2 = Go to another box 3 = Hang up	A prompt for the Item number refers to the box number. Enter the box number.
Account Number Box Setup	2002	Box associated with parameter number 2001	(Valid box number)	A prompt for the Item number refers to the box number. Enter the box number.
ACD Box Setup	2520	Number of mailbox that owns the ACD box	(Valid mailbox number)	A prompt for the Item number refers to the box number. Enter the box number.
ACD Box Setup	2521	Action to take when trying extension	1 = Blind 2 = Wait for answer 3 = Screen 4 = Wait for ring	A prompt for the Item number refers to the box number. Enter the box number.
ACD Box Setup	2522	Criteria by which hunt is started	0 = Start hunting from first agent in group 1 = Start hunting from previous agent	A prompt for the Item number refers to the box number. Enter the box number.
ACD Box Setup	2523	Number of announcements after which caller is offered other options	0 - 99	A prompt for the Item number refers to the box number. Enter the box number.
ACD Box Setup	2524	Rings permitted before no answer determination	0 - 99	A prompt for the Item number refers to the box number. Enter the box number.
ACD Box Setup	2525	Box default operator during day service	(Valid mailbox number)	A prompt for the Item number refers to the box number. Enter the box number.
ACD Box Setup	2526	Box default operator during night service	(Valid mailbox number)	A prompt for the Item number refers to the box number. Enter the box number.

Task	Param. Number	Description	Acceptable Values	Notes:
ACD Box Setup	2527	Action to take if all extensions are busy	0 = Queue the call 1 = Go to another box	A prompt for the Item number refers to the box number. Enter the box number.
ACD Box Setup	2528	Box associated with parameter 2527	(Valid box number)	A prompt for the Item number refers to the box number. Enter the box number.
ACD Box Setup	2529	Action to take if caller elects not to remain in queue	0 = Return 1 = Say 'Goodbye' 2 = Go to another box 3 = Hang up	A prompt for the Item number refers to the box number. Enter the box number.
ACD Box Setup	2530	Box associated with parameter 2529	(Valid box number)	A prompt for the Item number refers to the box number. Enter the box number.
ACD Box Setup	2531	If call is queued, state position in line?	1 = Yes 0 = No	A prompt for the Item number refers to the box number. Enter the box number.
ACD Box Setup	2501 to 2512	ACD rotation box members	(Valid mailbox numbers)	A prompt for the Item number refers to the box number. Enter the box number.
Business Hours Setup	5042	Hour day service begins	00-24	A prompt for the Item number refers to the day of the week. Enter 0 (Sunday) through 6 (Saturday).
Business Hours Setup	5043	(With parameter 5042) Minute day service begins	00 - 59	A prompt for the Item number refers to the day of the week. Enter 0 (Sunday) through 6 (Saturday).

Task	Param. Number	Description	Acceptable Values	Notes:
Business Hours Setup	5044	Hour day service ends	00 - 24	A prompt for the Item number refers to the day of the week. Enter 0 (Sunday) through 6 (Saturday).
Business Hours Setup	5045	(With parameter 5044) Minute day service ends	00 - 59	A prompt for the Item number refers to the day of the week. Enter 0 (Sunday) through 6 (Saturday).
Business Hours Setup	5046	Hour lunch service begins	00 - 24	A prompt for the Item number refers to the day of the week. Enter 0 (Sunday) through 6 (Saturday).
Business Hours Setup	5047	(With parameter 5046) Minute lunch service begins	00 - 59	A prompt for the Item number refers to the day of the week. Enter 0 (Sunday) through 6 (Saturday).
Business Hours Setup	5048	Hour lunch service ends	00 - 24	A prompt for the Item number refers to the day of the week. Enter 0 (Sunday) through 6 (Saturday).
Business Hours Setup	5049	(With parameter 5048) Minute lunch service ends	00 - 59	A prompt for the Item number refers to the day of the week. Enter 0 (Sunday) through 6 (Saturday).
Business Hours Setup	5067	Hour at which greeting is to change to good evening	00 - 24	A prompt for the Item number refers to the day of the week. Enter 0 (Sunday) through 6 (Saturday).

Task	Param. Number	Description	Acceptable Values	Notes:
Business Hours Setup	5068	(With parameter 5067) Minute at which greeting is to change to good evening	00 - 59	A prompt for the Item number refers to the day of the week. Enter 0 (Sunday) through 6 (Saturday).
Call Transfer Information Setup	5000	Sequence to initiate an internal transfer	(Refer to technical bulletin and phone documentation)	
Call Transfer Information Setup	5001	Sequence to initiate an external transfer	(Refer to technical bulletin and phone documentation)	
Call Transfer Information Setup	5002	Sequence to complete an internal transfer	(Refer to technical bulletin and phone documentation)	
Call Transfer Information Setup	5003	Sequence to complete an external transfer	(Refer to technical bulletin and phone documentation)	
Call Transfer Information Setup	5004	Sequence to return from no answer on an internal call	(Refer to technical bulletin and phone documentation)	
Call Transfer Information Setup	5005	Sequence to return from no answer on an external call	(Refer to technical bulletin and phone documentation)	
Call Transfer Information Setup	5006	Sequence to return from busy on an internal call	(Refer to technical bulletin and phone documentation)	
Call Transfer Information Setup	5007	Sequence to return from busy on an external call	(Refer to technical bulletin and phone documentation)	
Call Transfer Information Setup	5008	Sequence to return from call screening on an internal call	(Refer to technical bulletin and phone documentation)	
Call Transfer Information Setup	5009	Sequence to return from call screening on an external call	(Refer to technical bulletin and phone documentation)	
Call Transfer Information Setup	5010	Sequence to transfer an internal 3-way call	(Refer to technical bulletin and phone documentation)	
Call Transfer Information Setup	5011	Sequence to transfer an external 3-way call	(Refer to technical bulletin and phone documentation)	

Task	Param. Number	Description	Acceptable Values	Notes:
Call Transfer Information Setup	5014	Should VP system detect dial tone?	1 = Yes 0 = No	
Call Transfer Information Setup	5023	Confirmation digits meaning 'Yes'	(Refer to technical bulletin and phone documentation)	
Call Transfer Information Setup	5054	Should VP system use transfer bypass digit?	0 = None 1 = First 2 = Last	
Call Transfer Information Setup	5055	Maximum time for 3-way call (minutes)	0 - 30	
Class of Service Setup	7000	Number of days after which Old messages are auto-deleted	0 - 99	A prompt for the Item number refers to the Class of Service number. Enter 0 - 7.
Class of Service Setup	7001	Number of days after which New messages are auto-deleted	0 - 99	A prompt for the Item number refers to the Class of Service number. Enter 0 - 7.
Class of Service Setup	7002	Maximum message length (seconds) for a message	0 - 999	A prompt for the Item number refers to the Class of Service number. Enter 0 - 7.
Class of Service Setup	7003	Maximum number of messages allowed in mailbox	0 - 200	A prompt for the Item number refers to the Class of Service number. Enter 0 - 7.
Class of Service Setup	7004	Maximum greeting length (seconds)	0 - 999	A prompt for the Item number refers to the Class of Service number. Enter 0 - 7.
Class of Service Setup	7005	Maximum number of personal greetings allowed	0 - 10	A prompt for the Item number refers to the Class of Service number. Enter 0 - 7.

Task	Param. Number	Description	Acceptable Values	Notes:
Class of Service Setup	7006	Play menu after greeting to callers?	1 = Yes 0 = No	A prompt for the Item number refers to the Class of Service number. Enter 0 - 7.
Class of Service Setup	7007	Maximum lines allowed to hold for mailbox	0 - 32	A prompt for the Item number refers to the Class of Service number. Enter 0 - 7.
Class of Service Setup	7008	Number of times to try extension before returning to queued caller	0 - 99	A prompt for the Item number refers to the Class of Service number. Enter 0 - 7.
Class of Service Setup	7009	Say position in line to calls in queue?	1 = Yes 0 = No	A prompt for the Item number refers to the Class of Service number. Enter 0 - 7.
Class of Service Setup	7010	Access to Group boxes allowed?	1 = Yes 0 = No	A prompt for the Item number refers to the Class of Service number. Enter 0 - 7.
Class of Service Setup	7011	Supervisor status allowed?	1 = Yes 0 = No	A prompt for the Item number refers to the Class of Service number. Enter 0 - 7.
Class of Service Setup	7012	Caller access to P.A. system allowed?	1 = Yes 0 = No	A prompt for the Item number refers to the Class of Service number. Enter 0 - 7.
Class of Service Setup	7013	Dial-out allowed?	1 = Yes 0 = No	A prompt for the Item number refers to the Class of Service number. Enter 0 - 7.
Class of Service Setup	7014	Faxmail receipt allowed?	1 = Yes 0 = No	A prompt for the Item number refers to the Class of Service number. Enter 0 - 7.

Task	Param. Number	Description	Acceptable Values	Notes:
Class of Service Setup	7015	Default operator box during day service hours	(Valid mailbox number)	A prompt for the Item number refers to the Class of Service number. Enter 0 - 7.
Class of Service Setup	7016	Default operator box during night service hours	(Valid mailbox number)	A prompt for the Item number refers to the Class of Service number. Enter 0 - 7.
Class of Service Setup	7017	When exiting open mailbox, go to box #	(Valid box number)	A prompt for the Item number refers to the Class of Service number. Enter 0 - 7.
Class of Service Setup	7018	Digits callers can press while holding	1 - 9, #	A prompt for the Item number refers to the Class of Service number. Enter 0 - 7.
Class of Service Setup	7020 to 7029	Restricted outcalling numbers	(Any digits)	A prompt for the Item number refers to the Class of Service number. Enter 0 - 7.
Directory Box Setup	2001	Action to take if no digits are dialed	0 = Return 1 = Say 'Goodbye' 2 = Go to another box 3 = Hang up	A prompt for the Item number refers to the box number. Enter the box number.
Directory Box Setup	2002	Box associated with parameter 2001	(Valid box number)	A prompt for the Item number refers to the box number. Enter the box number.
Directory Box Setup	2600	Number of time to play greeting	1 - 3	A prompt for the Item number refers to the box number. Enter the box number.
Directory Box Setup	2601	Box associated with parameter 2602	(Valid box number)	A prompt for the Item number refers to the box number. Enter the box number.

Task	Param. Number	Description	Acceptable Values	Notes:
Directory Box Setup	2602	Action to take if requested name is not found	0 = Return 1 = Say 'Goodbye' 2 = Go to another box 3 = Hang up	A prompt for the Item number refers to the box number. Enter the box number.
Directory Box Setup	2603	Say box number before transferring call?	1 = Yes 0 = No	A prompt for the Item number refers to the box number. Enter the box number.
Directory Box Setup	2604	Allow callers to hear complete directory listing?	1 = Yes 0 = No	A prompt for the Item number refers to the box number. Enter the box number.
Directory Box Setup	2605	Maximum number of digits to collect from callers	1 - 9	A prompt for the Item number refers to the box number. Enter the box number.
General Information Setup	5017	Fast-forwarded / rewind seconds	0 - 10	
General Information Setup	5024	Technician password	Up to 10 digits	
General Information Setup	5025	Customer password	Up to 10 digits	
General Information Setup	5027	Digits needed to get line for external call	(Refer to technical bulletin and phone documentation)	
General Information Setup	5053	Store call log to:	0 = None 1 = File 2 = Printer	
General Information Setup	5056	(With parameter 5057) Maximum number of minutes call can last before being rerouted	0 - 30	
General Information Setup	5057	(With parameter 5056) Box to which calls are re-routed	(Valid box number)	

Task	Param. Number	Description	Acceptable Values	Notes:
General Information Setup	5065	Exit to DOS hour	00-23	
General Information Setup	5066	Exit to DOS minutes	00-59	
Group Box Setup	2800	Maximum length of a message (seconds) that can be sent to this box	10 - 999	A prompt for the Item number refers to the box number. Enter the box number.
Group Box Setup	2801 to 2850	Group box members	(Valid box numbers)	A prompt for the Item number refers to the box number. Enter the box number.
Holiday Schedule Setup	5050	(With parameter 5051) Holiday month	00-12	A prompt for the Item number refers to the holiday number. Enter 1 through 20.
Holiday Schedule Setup	5051	(With parameter 5050) Holiday date	01-31	A prompt for the Item number refers to the holiday number. Enter 1 through 20.
Holiday Schedule Setup	5052	Box to which calls are routed during holiday	(Valid box number)	A prompt for the Item number refers to the holiday number. Enter 1 through 20.
Line Information Setup	1000	Box to which calls on this line are routed during day service hours	(Valid box number)	A prompt for the Item number refers to the line number. Enter the line number.
Line Information Setup	1001	Box to which calls on this line are routed during night service hours	(Valid box number)	A prompt for the Item number refers to the line number. Enter the line number.

Task	Param. Number	Description	Acceptable Values	Notes:
Line Information Setup	1002	Box to which calls on this line are routed during lunch service hours	(Valid box number)	A prompt for the Item number refers to the line number. Enter the line number.
Line Information Setup	1003	Rings before call is answered during day service hours	1 - 99	A prompt for the Item number refers to the line number. Enter the line number.
Line Information Setup	1004	Rings before call is answered during night service hours	1 - 99	A prompt for the Item number refers to the line number. Enter the line number.
Line Information Setup	1005	Rings before call is answered during lunch service hours	1 - 99	A prompt for the Item number refers to the line number. Enter the line number.
Line Information Setup	1006	Outgoing calls allowed on this line?	1 = Yes 0 = No	A prompt for the Item number refers to the line number. Enter the line number.
Line Information Setup	1007	Line belongs to Line Group A?	1 = Yes 0 = No	A prompt for the Item number refers to the line number. Enter the line number.
Line Information Setup	1008	Line belongs to Line Group B?	1 = Yes 0 = No	A prompt for the Item number refers to the line number. Enter the line number.
Line Information Setup	1009	Line belongs to Line Group C?	1 = Yes 0 = No	A prompt for the Item number refers to the line number. Enter the line number.
Line Information Setup	1010	Line belongs to Line Group D?	1 = Yes 0 = No	A prompt for the Item number refers to the line number. Enter the line number.

Task	Param. Number	Description	Acceptable Values	Notes:
Mailbox Setup	2000	Mailbox owner's last name	(Digits that will allow the Dial-by-Name directory feature access this mailbox)	A prompt for the Item number refers to the box number. Enter the box number.
Mailbox Setup	2001	Action to be taken after caller leaves message	0 = Return 1 = Say 'Goodbye' 2 = Go to another box 3 = Hang up	A prompt for the Item number refers to the box number. Enter the box number.
Mailbox Setup	2002	Box associated with parameter 2001	(Valid box number)	A prompt for the Item number refers to the box number. Enter the box number.
Mailbox Setup	2100	Mailbox password	(Up to maximum digits specified during setup)	A prompt for the Item number refers to the box number. Enter the box number.
Mailbox Setup	2101	Sequence to turn on message waiting lamp	(See technical bulletin or phone documentation)	A prompt for the Item number refers to the box number. Enter the box number.
Mailbox Setup	2102	Sequence to turn off message waiting lamp	(See technical bulletin or phone documentation)	A prompt for the Item number refers to the box number. Enter the box number.
Mailbox Setup	2110	Box associated with parameter 2111	(Valid box number)	A prompt for the Item number refers to the box number. Enter the box number.
Mailbox Setup	2111	Action to be taken if caller chooses "other options"	0 = Return 1 = Say 'Goodbye' 2 = Go to another box 3 = Hang up	A prompt for the Item number refers to the box number. Enter the box number.

Task	Param. Number	Description	Acceptable Values	Notes:
Mailbox Setup	2112	Mailbox has access to only Hotel guest privileges?	1 = Yes 0 = No	A prompt for the Item number refers to the box number. Enter the box number. You can modify only one personal distribution list for the mailbox using the Teleparameter feature
Mailbox Setup	2113	Class of service assigned to mailbox	0 - 7	A prompt for the Item number refers to the box number. Enter the box number.
Mailbox Setup	2114	Mailbox to which this mailbox is a client, if this is a restricted mailbox	(Valid mailbox number)	A prompt for the Item number refers to the box number. Enter the box number.
Mailbox Setup	2115	Language in which greeting is to play if call is via D.I.D	0 - 9	A prompt for the Item number refers to the box number. Enter the box number.
Mailbox Setup	2120	Type of transfer	0 = None 1 = Blind 2 = Wait for answer 3 = Screen 4 = Wait for ring	A prompt for the Item number refers to the box number. Enter the box number.
Mailbox Setup	2121	Caller's name voiced upon pickup?	0 = No 1 = Yes	A prompt for the Item number refers to the box number. Enter the box number.
Mailbox Setup	2122	Number of rings within which called party must answer before system determines a no answer condition	Number of rings	A prompt for the Item number refers to the box number. Enter the box number.

Task	Param. Number	Description	Acceptable Values	Notes:
Mailbox Setup	2123	Call transfer schedule	0 = Always 1 = Day only 2 = Night only 3 = Schedule A 4 = Schedule B 5 = Schedule C 6 = Schedule D	A prompt for the Item number refers to the box number. Enter the box number.
Mailbox Setup	2124	3-way calling used	0 = Always 1 = Day only 2 = Night only 3 = Schedule A 4 = Schedule B 5 = Schedule C 6 = Schedule D	A prompt for the Item number refers to the box number. Enter the box number.
Mailbox Setup	2125	Record conversation?	1 = Yes 0 = No	A prompt for the Item number refers to the box number. Enter the box number.
Mailbox Setup	2126	Transfer destination	Extension number	A prompt for the Item number refers to the box number. Enter the box number.
Mailbox Setup	2130	(With parameter 2134) Type of pager	0 = None 1 = Tone-only pager (no display) 2 = Display pager	A prompt for the Item number refers to the box number. Enter the box number.
Mailbox Setup	2131	(With parameter 2134) Minutes between calls to pager	00 - 20	A prompt for the Item number refers to the box number. Enter the box number.
Mailbox Setup	2132	(With parameter 2134) Number of times to call pager	00 - 99	A prompt for the Item number refers to the box number. Enter the box number.
Mailbox Setup	2133	(With parameter 2134) Schedule during which calls should be sent to pager	0 = Always 1 = Day only 2 = Night only 3 = Schedule A 4 = Schedule B 5 = Schedule C 6 = Schedule D	A prompt for the Item number refers to the box number. Enter the box number.

Task	Param. Number	Description	Acceptable Values	Notes:
Mailbox Setup	2134	Mailbox owner's pager number	(Pager number)	A prompt for the Item number refers to the box number. Enter the box number.
Mailbox Setup	2141	Action to be taken after personal greeting is played	0 = Wait for a digit 1 = Begin recording a message 2 = Page the mailbox owner 3 = Record a message, then page the mailbox owner	A prompt for the Item number refers to the box number. Enter the box number.
Mailbox Setup	2142	Hours after which messages are to be auto-forwarded	0 - 999	A prompt for the Item number refers to the box number. Enter the box number.
Mailbox Setup	2143	(With parameter 2142) Box to which new messages are to be auto-forwarded	(Valid mailbox number)	A prompt for the Item number refers to the box number. Enter the box number.
Mailbox Setup	2144	(With parameters 2142 and 2143) Schedule during which auto-forwarding is to be active	0 = Always 1 = Day only 2 = Night only 3 = Schedule A 4 = Schedule B 5 = Schedule C 6 = Schedule D	A prompt for the Item number refers to the box number. Enter the box number.
Mailbox Setup	2151	(With parameter 2155) Number of times to run the message delivery cycle.	0 - 99	A prompt for the Item number refers to the box number. Enter the box number. You can modify only one message delivery set up for the mailbox using the Teleparameter feature.

Task	Param. Number	Description	Acceptable Values	Notes:
Mailbox Setup	2152	(With parameter 2155) Number of times number is to be called	0 - 99	A prompt for the Item number refers to the box number. Enter the box number. You can modify only one message delivery set up for the mailbox using the Teleparameter feature.
Mailbox Setup	2153	(With parameter 2155) Minutes in between calls to number	2 - 99	A prompt for the Item number refers to the box number. Enter the box number. You can modify only one message delivery set up for the mailbox using the Teleparameter feature.
Mailbox Setup	2154	(With parameter 2155) Schedule during which message delivery is active	0 = Always 1 = Day only 2 = Night only 3 = Schedule A 4 = Schedule B 5 = Schedule C 6 = Schedule D	A prompt for the Item number refers to the box number. Enter the box number. You can modify only one message delivery set up for the mailbox using the Teleparameter feature.
Mailbox Setup	2155	Number to call for message delivery	(Phone or beeper number)	A prompt for the Item number refers to the box number. Enter the box number. You can modify only one message delivery set up for the mailbox using the Teleparameter feature.

Task	Param. Number	Description	Acceptable Values	Notes:
Mailbox Setup	2159	Personal distribution list 1 enabled for mailbox?	1 = Yes 0 = No	A prompt for the Item number refers to the box number. Enter the box number. You can modify only one personal distribution list for the mailbox using the Teleparameter feature.
Mailbox Setup	2160 to 2179	Personal distribution list 1 members	(Valid mailbox numbers)	A prompt for the Item number refers to the box number. Enter the box number. You can modify only one personal distribution list for the mailbox using the Teleparameter feature.
Other Customizations Setup	5018	Maximum box length caller can dial	2 - 4	
Other Customizations Setup	5019	Seconds of initial pause before main greeting is played	0 - 10	
Other Customizations Setup	5020	When VP system should play time and date	0 = When caller asks 1 = Before each message 2 = After each message	
Other Customizations Setup	5021	Play called party's name when call is answered?	1 = Yes 0 = No	
Other Customizations Setup	5022	Announce call when call is answered?	1 = Yes 0 = No	
Other Customizations Setup	5076 to 5079	Custom field (use under direction of technical support)	---	
Other Customizations Setup	5086 to 5089	Debug field (use under direction of technical support)	---	

Task	Param. Number	Description	Acceptable Values	Notes:
Question Box Setup	2001	Action to take after questions are answered	0 = Return 1 = Say 'Goodbye' 2 = Go to another box 3 = Hang up	A prompt for the Item number refers to the box number. Enter the box number.
Question Box Setup	2002	Box associated with parameter 2404	(Valid box number)	A prompt for the Item number refers to the box number. Enter the box number.
Question Box Setup	2400	Number of mailbox that owns the Question box	(Valid mailbox number)	A prompt for the Item number refers to the box number. Enter the box number.
Question Box Setup	2401	Replay digit answers for verification?	1 = Yes 0 = No	A prompt for the Item number refers to the box number. Enter the box number.
Question Box Setup	2402	Voice answers? (versus digit)	1 = Yes 0 = No	A prompt for the Item number refers to the box number. Enter the box number.
Question Box Setup	2403	Trigger owner mailbox notification of answers in this box?	1 = Yes 0 = No	A prompt for the Item number refers to the box number. Enter the box number.
Question Box Setup	2404	Digits caller can press to exit this box	0 - 9, *, #	A prompt for the Item number refers to the box number. Enter the box number.
Question Box Setup	2410	Answer type for Question 10	0 = Voice 1 = Digits	A prompt for the Item number refers to the box number. Enter the box number.
Question Box Setup	2411	Answer type for Question 1	0 = Voice 1 = Digits	A prompt for the Item number refers to the box number. Enter the box number.

Task	Param. Number	Description	Acceptable Values	Notes:
Question Box Setup	2412	Answer type for Question 2	0 = Voice 1 = Digits	A prompt for the Item number refers to the box number. Enter the box number.
Question Box Setup	2413	Answer type for Question 3	0 = Voice 1 = Digits	A prompt for the Item number refers to the box number. Enter the box number.
Question Box Setup	2414	Answer type for Question 4	0 = Voice 1 = Digits	A prompt for the Item number refers to the box number. Enter the box number.
Question Box Setup	2415	Answer type for Question 5	0 = Voice 1 = Digits	A prompt for the Item number refers to the box number. Enter the box number.
Question Box Setup	2416	Answer type for Question 6	0 = Voice 1 = Digits	A prompt for the Item number refers to the box number. Enter the box number.
Question Box Setup	2417	Answer type for Question 7	0 = Voice 1 = Digits	A prompt for the Item number refers to the box number. Enter the box number.
Question Box Setup	2418	Answer type for Question 8	0 = Voice 1 = Digits	A prompt for the Item number refers to the box number. Enter the box number.
Question Box Setup	2419	Answer type for Question 9	0 = Voice 1 = Digits	A prompt for the Item number refers to the box number. Enter the box number.
Question Box Setup	2420	If the answer type is digits, minimum number of digits that must be entered for valid answer to question 10.	1 - 999	A prompt for the Item number refers to the box number. Enter the box number.

Task	Param. Number	Description	Acceptable Values	Notes:
Question Box Setup	2421	If the answer type is digits, minimum number of digits that must be entered for valid answer to question 1.	1 - 999	A prompt for the Item number refers to the box number. Enter the box number.
Question Box Setup	2422	If the answer type is digits, minimum number of digits that must be entered for valid answer to question 2.	1 - 999	A prompt for the Item number refers to the box number. Enter the box number.
Question Box Setup	2423	If the answer type is digits, minimum number of digits that must be entered for valid answer to question 3.	1 - 999	A prompt for the Item number refers to the box number. Enter the box number.
Question Box Setup	2424	If the answer type is digits, minimum number of digits that must be entered for valid answer to question 4.	1 - 999	A prompt for the Item number refers to the box number. Enter the box number.
Question Box Setup	2425	If the answer type is digits, minimum number of digits that must be entered for valid answer to question 5.	1 - 999	A prompt for the Item number refers to the box number. Enter the box number.
Question Box Setup	2426	If the answer type is digits, minimum number of digits that must be entered for valid answer to question 6.	1 - 999	A prompt for the Item number refers to the box number. Enter the box number.
Question Box Setup	2427	If the answer type is digits, minimum number of digits that must be entered for valid answer to question 7.	1 - 999	A prompt for the Item number refers to the box number. Enter the box number.
Question Box Setup	2428	If the answer type is digits, minimum number of digits that must be entered for valid answer to question 8.	1 - 999	A prompt for the Item number refers to the box number. Enter the box number.
Question Box Setup	2429	If the answer type is digits, minimum number of digits that must be entered for valid answer to question 9.	1 - 999	A prompt for the Item number refers to the box number. Enter the box number.

Task	Param. Number	Description	Acceptable Values	Notes:
Question Box Setup	2430	If the answer type is digits, maximum number of digits that can be entered for valid answer to question 10.	1 - 999	A prompt for the Item number refers to the box number. Enter the box number.
Question Box Setup	2431	If the answer type is digits, maximum number of digits that can be entered for valid answer to question 1.	1 - 999	A prompt for the Item number refers to the box number. Enter the box number.
Question Box Setup	2432	If the answer type is digits, maximum number of digits that can be entered for valid answer to question 2.	1 - 999	A prompt for the Item number refers to the box number. Enter the box number.
Question Box Setup	2433	If the answer type is digits, maximum number of digits that can be entered for valid answer to question 3.	1 - 999	A prompt for the Item number refers to the box number. Enter the box number.
Question Box Setup	2434	If the answer type is digits, maximum number of digits that can be entered for valid answer to question 4.	1 - 999	A prompt for the Item number refers to the box number. Enter the box number.
Question Box Setup	2435	If the answer type is digits, maximum number of digits that can be entered for valid answer to question 5.	1 - 999	A prompt for the Item number refers to the box number. Enter the box number.
Question Box Setup	2436	If the answer type is digits, maximum number of digits that can be entered for valid answer to question 6.	1 - 999	A prompt for the Item number refers to the box number. Enter the box number.
Question Box Setup	2437	If the answer type is digits, maximum number of digits that can be entered for valid answer to question 7.	1 - 999	A prompt for the Item number refers to the box number. Enter the box number.
Question Box Setup	2438	If the answer type is digits, maximum number of digits that can be entered for valid answer to question 8.	1 - 999	A prompt for the Item number refers to the box number. Enter the box number.

Task	Param. Number	Description	Acceptable Values	Notes:
Question Box Setup	2439	If the answer type is digits, maximum number of digits that can be entered for valid answer to question 9.	1 - 999	A prompt for the Item number refers to the box number. Enter the box number.
Question Box Setup	2440	Number of seconds of silence before VP system determines caller has finished entering digits or speaking the answer for question 10.	1 - 99	A prompt for the Item number refers to the box number. Enter the box number.
Question Box Setup	2441	Number of seconds of silence before VP system determines caller has finished entering digits or speaking the answer for question 1.	1 - 99	A prompt for the Item number refers to the box number. Enter the box number.
Question Box Setup	2442	Number of seconds of silence before VP system determines caller has finished entering digits or speaking the answer for question 2.	1 - 99	A prompt for the Item number refers to the box number. Enter the box number.
Question Box Setup	2443	Number of seconds of silence before VP system determines caller has finished entering digits or speaking the answer for question 3.	1 - 99	A prompt for the Item number refers to the box number. Enter the box number.
Question Box Setup	2444	Number of seconds of silence before VP system determines caller has finished entering digits or speaking the answer for question 4.	1 - 99	A prompt for the Item number refers to the box number. Enter the box number.
Question Box Setup	2445	Number of seconds of silence before VP system determines caller has finished entering digits or speaking the answer for question 5.	1 - 99	A prompt for the Item number refers to the box number. Enter the box number.

Task	Param. Number	Description	Acceptable Values	Notes:
Question Box Setup	2446	Number of seconds of silence before VP system determines caller has finished entering digits or speaking the answer for question 6.	1 - 99	A prompt for the Item number refers to the box number. Enter the box number.
Question Box Setup	2447	Number of seconds of silence before VP system determines caller has finished entering digits or speaking the answer for question 7.	1 - 99	A prompt for the Item number refers to the box number. Enter the box number.
Question Box Setup	2448	Number of seconds of silence before VP system determines caller has finished entering digits or speaking the answer for question 8.	1 - 99	A prompt for the Item number refers to the box number. Enter the box number.
Question Box Setup	2449	Number of seconds of silence before VP system determines caller has finished entering digits or speaking the answer for question 9.	1 - 99	A prompt for the Item number refers to the box number. Enter the box number.
Routing Box Setup	2001	Action to take if no digits dialed	0 = Return 1 = Say 'Goodbye' 2 = Go to another box 3 = Hang up	
Routing Box Setup	2002	Box associated with parameter 2001	(Valid box number)	
Routing Box Setup	2300	Single-digit dialing destination for digit 0	(Valid box number)	A prompt for the Item number refers to the box number. Enter the box number.
Routing Box Setup	2301	Single-digit dialing destination for digit 1	(Valid box number)	A prompt for the Item number refers to the box number. Enter the box number.
Routing Box Setup	2302	Single-digit dialing destination for digit 2	(Valid box number)	A prompt for the Item number refers to the box number. Enter the box number.

Task	Param. Number	Description	Acceptable Values	Notes:
Routing Box Setup	2303	Single-digit dialing destination for digit 3	(Valid box number)	A prompt for the Item number refers to the box number. Enter the box number.
Routing Box Setup	2304	Single-digit dialing destination for digit 4	(Valid box number)	A prompt for the Item number refers to the box number. Enter the box number.
Routing Box Setup	2305	Single-digit dialing destination for digit 5	(Valid box number)	A prompt for the Item number refers to the box number. Enter the box number.
Routing Box Setup	2306	Single-digit dialing destination for digit 6	(Valid box number)	A prompt for the Item number refers to the box number. Enter the box number.
Routing Box Setup	2307	Single-digit dialing destination for digit 7	(Valid box number)	A prompt for the Item number refers to the box number. Enter the box number.
Routing Box Setup	2308	Single-digit dialing destination for digit 8	(Valid box number)	A prompt for the Item number refers to the box number. Enter the box number.
Routing Box Setup	2309	Single-digit dialing destination for digit 9	(Valid box number)	A prompt for the Item number refers to the box number. Enter the box number.
Routing Box Setup	2310	Single-digit dialing destination for *	(Valid box number)	A prompt for the Item number refers to the box number. Enter the box number.
Routing Box Setup	2311	Single-digit dialing destination for #	(Valid box number)	A prompt for the Item number refers to the box number. Enter the box number.

Task	Param. Number	Description	Acceptable Values	Notes:
Routing Box Setup	2312	Single-digit dialing destination for non-DTMF digit (voice)	(Valid box number)	A prompt for the Item number refers to the box number. Enter the box number.
Routing Box Setup	2313	Number of mailbox that owns the Routing box	(Valid box number)	
Routing Box Setup	2314	Box to which calls are transferred if invalid digits dialed	(Valid box number)	A prompt for the Item number refers to the box number. Enter the box number.
Routing Box Setup	2315	Number of times to play greeting	1 - 3	
Routing Box Setup	2316	Seconds to wait for a digit	0 - 9	
Routing Box Setup	2317	Basis used to route call	0 = Digits dialed 1 = Day of week 2 = Sequence number 3 = Database lookup 4 = Day or Night service	A prompt for the Item number refers to the box number. Enter the box number.
Routing Box Setup	2318	When digits received, wait for more digits?	1 = Yes 0 = No	A prompt for the Item number refers to the box number. Enter the box number.
Technical Information Setup	5012	Hookflash length (milliseconds)	100 - 5000	
Technical Information Setup	5013	Pause length (milliseconds)	10 - 5000	
Technical Information Setup	5015	Seconds of silence before VP system ends recording	0 - 99	
Technical Information Setup	5016	Seconds of non-silence before VP system ends recording	0 - 99	
Technical Information Setup	5026	Disconnect digit sequence	(Refer to technical bulletin and phone documentation)	

Task	Param. Number	Description	Acceptable Values	Notes:
Technical Information Setup	5063	Hour at which system automatically updates MWI	00 - 23	
Technical Information Setup	5064	(With parameter 5063) Minute at which system automatically updates MWI	00 - 59	
VM.CFG Setup	9001	transbypass=	See the Installation Manual.	
VM.CFG Setup	9003	dtmfon=	See the Installation Manual.	
VM.CFG Setup	9004	ignorenonsilence	See the Installation Manual.	
VM.CFG Setup	9007	internal=	See the Installation Manual.	
VM.CFG Setup	9011	pagetime=	See the Installation Manual.	
VM.CFG Setup	9012	pagerretry=	See the Installation Manual.	
VM.CFG Setup	9014	maxpasswordlength=	See the Installation Manual.	
VM.CFG Setup	9015	greetsil=	See the Installation Manual.	
VM.CFG Setup	9017	notifyreps=	See the Installation Manual.	
VM.CFG Setup	9019	interdigit=	See the Installation Manual.	
VM.CFG Setup	9023	detectpulse	See the Installation Manual.	
VM.CFG Setup	9025	auditdatabase	See the Installation Manual.	
VM.CFG Setup	9026	responsetime=	See the Installation Manual.	
VM.CFG Setup	9099	pa.init=	See the Installation Manual.	
VM.CFG Setup	9100	pa.cancel=	See the Installation Manual.	
VM.CFG Setup	9101	tutorialreps=	See the Installation Manual.	
VM.CFG Setup	9102	pa.repeats=	See the Installation Manual.	

Task	Param. Number	Description	Acceptable Values	Notes:
VM.CFG Setup	9103	novideomemory	See the Installation Manual.	
VM.CFG Setup	9104	offhookdelay=	See the Installation Manual.	
VM.CFG Setup	9105	hardwareint=	See the Installation Manual.	
VM.CFG Setup	9106	ringon=	See the Installation Manual.	
VM.CFG Setup	9107	minimummessage=	See the Installation Manual.	
VM.CFG Setup	9108	maxinactive=	See the Installation Manual.	
VM.CFG Setup	9109	maxlockup=	See the Installation Manual.	
VM.CFG Setup	9118	languages=	See the Installation Manual.	
VM.CFG Setup	9120	dtmfsendon=	See the Installation Manual.	
VM.CFG Setup	9121	dtmfsendoff=	See the Installation Manual.	
VM.CFG Setup	9122	pa.busy=	See the Installation Manual.	
VM.CFG Setup	9123	lunchoperatorisday	See the Installation Manual.	
VM.CFG Setup	9124	samplingrate=	See the Installation Manual.	
VM.CFG Setup	9125	databaseline=	See the Installation Manual.	
VM.CFG Setup	9126	ignoredisconnects	See the Installation Manual.	
VM.CFG Setup	9127	nonamettransfer	See the Installation Manual.	
VM.CFG Setup	9135	norecordbeep	See the Installation Manual.	
VM.CFG Setup	9144	repeatmw=	See the Installation Manual.	
VM.CFG Setup	9146	deleteafterfwd	See the Installation Manual.	
VM.CFG Setup	9150	remotepause=	See the Installation Manual.	

Task	Param. Number	Description	Acceptable Values	Notes:
VM.CFG Setup	9160	ringreset=	See the Installation Manual.	
VM.CFG Setup	9161	notifyingrs=	See the Installation Manual.	
VM.CFG Setup	9162	assumepageconfirm	See the Installation Manual.	
VM.CFG Setup	9163	assumehold=	See the Installation Manual.	
VM.CFG Setup	9165	externalfax	See the Installation Manual.	
VM.CFG Setup	9166	faxtimeout=	See the Installation Manual.	
VM.CFG Setup	9167	nopcbeep	See the Installation Manual.	
VM.CFG Setup	9174	cdspeed=	See the Installation Manual.	
VM.CFG Setup	9182	ignoreinitialdisconnect	See the Installation Manual.	
VM.CFG Setup	9190	lineaccessontransfer	See the Installation Manual.	
VM.CFG Setup	9192	24hourclockdisplay	See the Installation Manual.	
VM.CFG Setup	9203	linesconnected=	See the Installation Manual.	
VM.CFG Setup	9206	qboxposconfirm	See the Installation Manual.	
VM.CFG Setup	9207	qboxdataprint	See the Installation Manual.	
VM.CFG Setup	9208	qboxarchive	See the Installation Manual.	
VM.CFG Setup	9209	pagerprefix=	See the Installation Manual.	
VM.CFG Setup	9210	pagerappend=	See the Installation Manual.	
VM.CFG Setup	9214	omitgroupsender	See the Installation Manual.	
VM.CFG Setup	9216	pagertrail=	See the Installation Manual.	
VM.CFG Setup	9218	longhookflash=	See the Installation Manual.	

Task	Param. Number	Description	Acceptable Values	Notes:
VM.CFG Setup	9219	cp.dialtone=	See the Installation Manual.	
VM.CFG Setup	9220	cp.busy=	See the Installation Manual.	
VM.CFG Setup	9221	cp.invalid=	See the Installation Manual.	
VM.CFG Setup	9222	cp.dnd=	See the Installation Manual.	
VM.CFG Setup	9223	cp.ans=	See the Installation Manual.	
VM.CFG Setup	9224	cp.initring=	See the Installation Manual.	
VM.CFG Setup	9225	cp.interring=	See the Installation Manual.	
VM.CFG Setup	9226	cp.noans=	See the Installation Manual.	
VM.CFG Setup	9227	onhookdtmf	See the Installation Manual.	
VM.CFG Setup	9229	answerack=	See the Installation Manual.	
VM.CFG Setup	9232	senddisconnect=	See the Installation Manual.	
VM.CFG Setup	9256	playbackdelay=	See the Installation Manual.	
VM.CFG Setup	9273	cp.disconnect=	See the Installation Manual.	
VM.CFG Setup	9282	qboxdataprntejct	See the Installation Manual.	
VM.CFG Setup	9283	qboxuseconfirmnumbers	See the Installation Manual.	
VM.CFG Setup	9289	qboxhideacctnumbers	See the Installation Manual.	
VM.CFG Setup	9291	keepmessagesnew	See the Installation Manual.	
VM.CFG Setup	9295	pooledring=	See the Installation Manual.	
VM.CFG Setup	9296	mboxdefaultdigit=	See the Installation Manual.	
VM.CFG Setup	9301	greeting.noanswer=	See the Installation Manual.	

Task	Param. Number	Description	Acceptable Values	Notes:
VM.CFG Setup	9302	greeting.busy=	See the Installation Manual.	
VM.CFG Setup	9303	greeting.dnd=	See the Installation Manual.	
VM.CFG Setup	9337	noaccountinlog	See the Installation Manual.	
VM.CFG Setup	9339	greeting.night=	See the Installation Manual.	
VM.CFG Setup	9340	faxpause=	See the Installation Manual.	
VM.CFG Setup	9342	samecallfaxok	See the Installation Manual.	
VM.CFG Setup	9343	mwonreps=	See the Installation Manual.	
VM.CFG Setup	9344	mwoffreps=	See the Installation Manual.	
VM.CFG Setup	9346	faxprefix=	See the Installation Manual.	
VM.CFG Setup	9349	faxgeneraldelivery=	See the Installation Manual.	
VM.CFG Setup	9351	initialpauseidp=	See the Installation Manual.	
VM.CFG Setup	9352	directoryidp=	See the Installation Manual.	
VM.CFG Setup	9353	messagepausetime=	See the Installation Manual.	
VM.CFG Setup	9354	sharefaxports	See the Installation Manual.	
VM.CFG Setup	9359	flowcontrol=	See the Installation Manual.	
VM.CFG Setup	9360	fastacdtransfer	See the Installation Manual.	
VM.CFG Setup	9361	pmsviatestfiles	See the Installation Manual.	
VM.CFG Setup	9364	serviceobservecode=	See the Installation Manual.	
VM.CFG Setup	9365	acdpause=	See the Installation Manual.	
VM.CFG Setup	9383	wakeuprings=	See the Installation Manual.	

Task	Param. Number	Description	Acceptable Values	Notes:
VM.CFG Setup	9384	ivrpromptlanguage=	See the Installation Manual.	
VM.CFG Setup	9388	volume=	See the Installation Manual.	
VM.CFG Setup	9389	noserialmwrefresh	See the Installation Manual.	
VM.CFG Setup	9390	basiccptones	See the Installation Manual.	
VM.CFG Setup	9392	extrarotarytime=	See the Installation Manual.	
VM.CFG Setup	9393	transferring=	See the Installation Manual.	
VM.CFG Setup	9394	dialtonefrequency=	See the Installation Manual.	
VM.CFG Setup	9395	dialtone2frequency=	See the Installation Manual.	
Serial Number	4000	Voices the system's serial number.	—	
NUMLINES.TXT	4001	Adjusts the code number authorizing the number of ports allowed.	(Code supplied by Sales / Tech. Support)	Code found on invoice.
SWITCHES.TXT	4002	Adjusts the code number authorizing the software for system features.	(Code supplied by Sales / Tech. Support)	Code found on invoice.
LOGINS.TXT	4003	Adjusts the code number that controls the number of VCM logins allowed.	(Code supplied by Sales / Tech. Support)	Code found on invoice.
PBXLINK.TXT	4004	Adjusts the code number authorizing the software for certain phone system-related features.	(Code supplied by Sales / Tech. Support)	Code found on invoice.

The following table identifies additional values you can specify to indicate special characters or information in some fields:

Values	Indicate
***1	A
***2	B

Values	Indicate
***3	C
***4	D
***5	E
***6	F
***7	X
***8	Pause
***9	Hookflash
***0	Clears the field entry

2.7.3 Using the Teleparameter Feature to Adjust the System Setup

You can use the Teleparameter feature to adjust the system setup at any time. It is not necessary to bring down the system to make modifications. To use the Teleparameter feature to adjust information, follow steps 1 through 4 in the procedure in **section 2.7.1.2**. For specific parameters you can adjust, refer to **section 2.7.1.2**. For detailed information, refer to the *Installation and Maintenance Manual*.

Note: If you enter a parameter number for a parameter that affects a particular box, the system prompts you to enter the **Item number**. The Item number identifies the particular box in which you want to change the parameter. At the Item number prompt, enter the **number of the box**.

Note: Refer to **section 2.7.2** for information on values you can specify for certain parameters and for information on adjusting parameters in the VM.CFG file. For detailed information on each field of System Information or Box Setup screens, refer to the *Installation and Maintenance Manual*.

Be advised that many day-to-day modifications that must be made to the system (adding mailboxes, changing system greetings, making call routing modifications) can be done by calling into the supervisor mailbox and selecting options from the Supervisor menu. By using Supervisor menu options, you do not need to refer to specific parameter numbers and

values. For information on day-to-day modifications that can be made using Supervisor menu options (and not the Teleparameter feature), refer to **section 3**.

2.8 Upgrading 2 Port Systems to 4 Ports

You can upgrade 2-port Lite systems to function as 4-port systems. Contact the Lite system sales representative for information. When you purchase a system port upgrade, you are provided a code number (located on the invoice), which you must enter into the Lite system. This code enables the additional 2 ports for service.

To enter the upgrade code, use teleparameter 4001 as described earlier in this document. When prompted, simply enter the code provided on the invoice.

Note: On a Debut unit, a small sticker on the underside of the unit includes a number that can identify whether the unit is configured for 2 ports or 4 ports and whether it is an analog or digital system as follows:

If the sticker begins with:	The system is:
96-0612-	2 port, analog
96-0532-	4 port, analog
96-0584-	4 port, digital

3. System Supervisor Instructions

The procedures provided in this section indicate how a system supervisor can make changes to the system setup by calling into the system using a telephone. Each of these procedures can also be performed by accessing the Lite system software screens through a serial connection to a laptop PC. For procedures on making modifications through the screen interface, refer to procedures earlier in this document, or to the *Installation and Maintenance Manual* or *Supervisor's Guide*.

3.1 Working with Mailboxes

3.1.1 Adding, Deleting, or Modifying a Mailbox

1. From a telephone, call into voice mail and log into the **supervisor mailbox 70**. The system voices the Main menu:

“To listen to your messages press 1. To send a message press 2. To change your options press 3.”

2. To access the Supervisor menu, **press 6** (this option is not voiced). The system voices the Supervisor menu options:

Supervisor Menu	
For Mailbox Administration	Press 1
For Routing Box Administration	Press 2
For Question Box Administration	Press 3
For Port Administration	Press 4
To Change the System Broadcast Message	Press 5
To Change the Voice Mail Day / Night Service	Press 6
To Change the System Time	Press 7
To Change the System Date	Press 8
To Modify System Parameters	Press 9
To Perform First-Time Setup	Press 0

3. From the Supervisors menu, **press 1** for Mailbox Administration.
4. When prompted, **enter the number of the mailbox** you want to add, modify, or delete. The system voices the number back to you.
5. When prompted, **press 1** to confirm the number you entered or press # if the number you entered was incorrect. Once you press 1 to confirm, the system voices the Mailbox menu options:

Mailbox Menu	
To Add	Press 1
To Delete	Press 2
To Modify	Press 3
To Suspend	Press 4
To Restore	Press 5
To Reset	Press 6
To Exit	Press #

6. To add a new the mailbox to the system, **press 1**. The system adds the new mailbox to the mailbox database. All default settings in the mailbox are set to the default parameters settings specified in prototype mailbox 9994. The default password for the mailbox is the same as the mailbox number.

To delete the mailbox from the system, **press 2**. The system deletes the mailbox from the mailbox database.

To modify the mailbox on the system, **press 3**. The system voices the Options menu:

Options Menu	
To Record Your Name	Press 1
To Record Your Greeting	Press 2
To Change Your Password	Press 3
To Change Your Call-Transfer Feature	Press 4
To Change Your Message Notification Feature	Press 5
To Change Your Pager Feature	Press 6
To Review Msgs Scheduled for Future Delivery	Press 7
To Change your Personal Distribution Lists	Press 8
To Retrieve a Message Previously Sent	Press *
To Return to the Main Menu	Press #

7. To record the mailbox owner's name, **press 1**. (Note that each mailbox owner can also log into the mailbox and complete this task—this does not need to be performed by a system supervisor.)
8. Once you record the name, the system voices the following prompts:

To Replay	Press 1
To Re-Record	Press 2
To Delete	Press 3
To Exit	Press #

Follow the prompts to complete the procedure.

9. To record a personal greeting for the mailbox, **press 2**. You can record up to 10 personal greetings for the mailbox (0 through 9). (Note that each mailbox owner can also log into the mailbox and complete this task—this does not need to be performed by a system supervisor.)
10. Once you record a greeting, the system voices the following prompts:

To Replay the Greeting	Press 1
To Re-Record the Greeting	Press 2
To Delete the Greeting	Press 3
To Choose a New Greeting	Press 5
To Exit	Press #

Follow the prompts to complete the procedure.

11. To change the mailbox password, **press 3**. Note that to change the password, you must first enter the current password when prompted by the system. By default, the mailbox password is the same as the mailbox number. (Also note that each mailbox owner can log into the mailbox and complete this task—this does not need to be performed by a system supervisor.)

Once you enter a new mailbox password and confirm the entry as prompted, the system voices a prompt informing you that the new password will be in effect the next time the mailbox is accessed.

12. To change the call transfer feature, **press 4**. (Note that each mailbox owner can also log into the mailbox and complete this task—this does not need to be performed by a system supervisor.)
13. The system voices a prompt identifying the current call transfer set up, then voices the call transfer options:

Press 1 if you would like to change the number Press * to turn this feature on or off, or Press # if you are satisfied
--

Follow the prompts to complete the procedure.

14. To change the message notification feature, **press 5**. (Note that each mailbox owner can also log into the mailbox and complete this task—this does not need to be performed by a system supervisor.)
15. The system voices a prompt identifying the current message notification setup, then voices the notification options:

Press 1 if you would like to change the number
Press * to turn this feature on or off, or
Press # if you are satisfied

Follow the prompts to complete the procedure.

16. To change the pager feature, **press 6**. (Note that each mailbox owner can also log into the mailbox and complete this task—this does not need to be performed by a system supervisor.)
17. The system voices a prompt identifying the current pager set up, then voices the paging options:

Press 1 if you would like to change the number
Press * to turn this feature on or off, or
Press # if you are satisfied

Follow the prompts to complete the procedure.

18. To review messages scheduled for future delivery, **press 7**. (Note that each mailbox owner can also log into the mailbox and complete this task—this does not need to be performed by a system supervisor.)

19. The system voices a prompt identifying any message scheduled for future delivery, then voices the options:

To Listen to the Message	Press 1
To Hear the Next Message (scheduled for future delivery)	Press 2
To Cancel the Message	Press 4
To Exit	Press #

Follow the prompts to complete the procedure.

3.2 Working with Routing Boxes

3.2.1 Understanding the Routing Box Setup

The Lite system is pre-configured with 3 Routing boxes to process calls. Routing box 800 answers calls during office open business hours (specified as “day service” hours during set up), box 801 answers calls after day service hours, and box 821 routes calls after they have already passed through box 800 or 801.

During set up, the following greetings were recorded in Routing boxes 800, 801, and 821:

Box	Greeting Number	Information Voiced by Greeting
800	Greeting 0	Office Open greeting and call routing options
800	Greeting 1	Holiday greeting and call routing options
801	Greeting 0	Office Closed greeting and call routing options
801	Greeting 1	Holiday greeting and call routing options
821	Greeting 0	Call routing options

Typically, companies offer more extensive call routing options to callers during open hours than during closed hours. Often, single-digit call routing (for example, “...*Press 2 for*

Sales... ”) is not offered during office closed hours, therefore the prompts and call routing options differ between box 800 and 801.

To accommodate the fact that a holiday lasts a full 24 hours, and thus holiday calls are answered by both box 800 and 801 throughout those 24 hours, a holiday greeting is provided in both box 800 and 801.

Box 800, Greeting 0 Example:

“Welcome to [Company]. If you know the extension number of the person to whom you want to speak, dial it now. For a directory, press star. Or press zero for the operator.”

<p>Note: If the system is set up to provide callers single-digit call routing options (“...Press 2 for Sales...”), those options are also voiced to callers during this greeting.</p>
--

Box 800, Greeting 1 Example:

“[Company] is closed today for the holiday. To leave a message for a specific individual, dial the party’s extension now. For a directory, press star. If you would like to leave your message with the operator, press zero now.”

Box 801, Greeting 0 Example:

“[Company] is presently closed. To leave a message for a specific individual, dial the party’s extension now. For a directory, press star. If you would like to leave your message with the operator, press zero now.”

Box 801, Greeting 1 Example:

“[Company] is closed today for the holiday. To leave a message for a specific individual, dial the party’s extension now. For a directory, press star. If you would like to leave your message with the operator, press zero now.”

Box 821, Greeting 0 Example:

“If you know the extension number of the person to whom you want to speak, dial it now. For a directory, press star. Or press zero for the operator.”

Note: If the system is set up to provide callers single-digit call routing options (“...Press 2 for Sales...”), those options are also voiced to callers during this greeting.

Other Greetings

Up to 10 different greetings can be recorded and stored in each Routing box. Procedures for recording additional greetings and changing the currently active greeting in each box are provided later in this section. The chart below is provided for you to note any additional greetings set up on the system:

Box	Greeting Number	Greeting

3.2.2 Recording Routing Box Greetings or Changing Currently Active Greetings

1. From a telephone, call into voice mail and log into the **supervisor mailbox 70**. The system voices the Main menu:

“To listen to your messages press 1. To send a message press 2. To change your options press 3.”

2. **Press 3** to change options. The system voices the Options menu:

Options Menu	
To Record Your Name	Press 1
To Record Your Greeting	Press 2
To Change Your Password	Press 3
To Change Your Call-Transfer Feature	Press 4
To Change Your Message Notification Feature	Press 5
To Change Your Pager Feature	Press 6
To Review Msgs scheduled for Future Delivery	Press 7
To Change Your Personal Distribution Lists	Press 8
To Retrieve a Message Previously Sent	Press *
To Return to the Main Menu	Press #

3. From the Options menu, **press 2**.
4. When prompted, **enter the number of the Routing box** whose greeting you want to change. (Note that to change a Routing box greeting, you must be logged into the mailbox that is the designated owner of the Routing box, as specified on the Routing box's setup screen. By default, Supervisor mailbox 70 is the owner of Routing boxes 800, 801, and 821.)

5. When prompted, **press 1** to confirm the number you entered or press # if the number you entered was incorrect. Once you press 1 to confirm, the system voices the following options, which relate to the currently active greeting:

To Replay the Greeting	Press 1
To Re-Record the Greeting	Press 2
To Delete the Greeting	Press 3
To Choose a New Greeting	Press 5
To Exit	Press #

6. If you intend to re-record the greeting, first press 1 to replay it. By replaying the greeting you can 1) ensure you are re-recording the greeting you intended to modify, and 2) note all the call routing options that are currently provided in the greeting so you can restate the appropriate call routing options in the new greeting you record (for example, "...*Press 2 for Sales...*"). Note that you can modify the single-digit call routing options by following the procedure provided later in this section.
7. To re-record the greeting, **press 2**. The system prompts you to enter the number of the greeting you want to re-record. Enter the greeting number (0 through 9). Then, follow the prompts to complete the procedure.
8. To choose a new greeting to play as the currently active greeting, **press 5**. The system prompts you to enter the number of the greeting you would like to activate or to press star for the currently active greeting. If you press *, the system voices the currently active greeting number and greeting, then re-voices the options:

To Replay the Greeting	Press 1
To Re-Record the Greeting	Press 2
To Delete the Greeting	Press 3
To Choose a New Greeting	Press 5
To Exit	Press #

9. Once you press 5 and enter a new greeting number, the system voices a confirmation prompt stating the greeting number and voicing the now-active greeting.

3.2.3 Changing the Single-Digit Call Routing

The Lite system can be set up to voice greetings to callers that include single-digit call routing options, such as, “*Press 2 for Sales...*” On a system set up this way, a call is transferred to a certain mailbox when the caller presses 2 during or after the greeting. You can control the digit(s) callers can dial and the route their calls will subsequently take using the following procedure.

Note that if you use the following procedure to change the single-digit call routing set up, you must update the Routing box greeting to relay new instructions to the caller. Use the procedure in **section 3.2.2** to update the greeting as necessary.

1. From a telephone, call into voice mail and log into the **supervisor mailbox 70**. The system voices the Main menu:

“To listen to your messages press 1. To send a message press 2. To change your options press 3.”

2. To access the Supervisor menu, **press 6** (this option is not voiced). The system voices the Supervisor menu options:

Supervisor Menu	
For Mailbox Administration	Press 1
For Routing Box Administration	Press 2
For Question Box Administration	Press 3
For Port Administration	Press 4
To Change the System Broadcast Message	Press 5
To Change the Voice Mail Day / Night Service	Press 6
To Change the System Time	Press 7
To Change the System Date	Press 8
To Modify System Parameters	Press 9
To Perform First-Time Setup	Press 0
To Exit	Press #

3. From the Supervisors menu, **press 2** for Routing box Administration.
4. When prompted, **enter the number of the Routing box** with which you want to work.

5. When prompted, **press 1** to confirm the number you entered or press # if the number you entered was incorrect. Once you press 1 to confirm, the system voices the Routing Box administration menu options:

Routing Box Menu	
To Add	Press 1
To Delete	Press 2
To Modify	Press 3
To Exit	Press #

6. To make modifications to the Routing box, **press 3**. The system voices the modification options:

To Change the Greeting	Press 1
To Change the Routing	Press 2
To Exit	Press #

7. To change the routing structure, **press 2**. The system voices the prompt, *“For digits zero through nine, please enter the digit, or press * for special routing options.”*
8. **Press the digit** for which you want to modify the call routing. The system voices a prompt identifying the current call routing set up for the digit.
9. When prompted, **press 1** to change the routing for the digit. Then, when prompted, enter the number of the box to which you now want callers who press the digit to route. The system voices a prompt stating the new call routing structure.

Note that you can make special call routing refinements by pressing * in step 8 above. The system voices the following special routing options:

To Change the Destination for the Star Digit	Press *
To Change the Destination for the Pound Digit	Press #
To Change the No Digits Destination	Press 1
To Change the Invalid Digit Destination	Press 2
To Change the Voice Detected Destination	Press 3

Once you access this menu, be advised that you must not press # to exit it, since the # key invokes a change to the destination for the pound key. If you want to return to the previous menu, simply make no entry when you hear the special routing options prompt.

3.3 General System Maintenance

3.3.1 Enabling or Disabling a Port

1. From a telephone, call into voice mail and log into the **supervisor mailbox 70**. The system voices the Main menu:

“To listen to your messages press 1. To send a message press 2. To change your options press 3.”

2. To access the Supervisor menu, **press 6** (this option is not voiced). The system voices the Supervisor menu options:

Supervisor Menu	
For Mailbox Administration	Press 1
For Routing Box Administration	Press 2
For Question Box Administration	Press 3
For Port Administration	Press 4
To Change the System Broadcast Message	Press 5
To Change the Voice Mail Day / Night Service	Press 6
To Change the System Time	Press 7
To Change the System Date	Press 8
To Modify System Parameters	Press 9
To Perform First-Time Setup	Press 0
To Exit	Press #

3. From the Supervisors menu, **press 4** for Port Administration.
4. When prompted, enter the **number of the line** with which you want to work.

5. When prompted, **press 1** to confirm the number you entered or press # if the number you entered was incorrect. Once you press 1 to confirm, the system voices the port administration options:

To Disable a Port	Press 1
To Enable a Port	Press 2
To Exit	Press #

6. To shut down a port, **press 1** to disable it. If you disable a port, all calls using that port are immediately terminated.
7. To enable a port that is currently shut down, **press 2**.

3.3.2 Recording a Broadcast Message for All Mailboxes

A broadcast message is automatically sent to every mailbox on the system. The message is played to the mailbox owners the first time they log into their mailbox following the recording of the broadcast message. A broadcast message does not activate any message waiting lights or indicators on subscriber telephones and does not add to the message count of new or old messages in subscriber mailboxes.

1. From a telephone, call into voice mail and log into the **supervisor mailbox 70**. The system voices the Main menu:

“To listen to your messages press 1. To send a message press 2. To change your options press 3.”

- To access the Supervisor menu, **press 6** (this option is not voiced). The system voices the Supervisor menu options:

Supervisor Menu	
For Mailbox Administration	Press 1
For Routing Box Administration	Press 2
For Question Box Administration	Press 3
For Port Administration	Press 4
To Change the System Broadcast Message	Press 5
To Change the Voice Mail Day / Night Service	Press 6
To Change the System Time	Press 7
To Change the System Date	Press 8
To Modify System Parameters	Press 9
To Perform First-Time Setup	Press 0
To Exit	Press #

- From the Supervisors menu, **press 5** for System Broadcast Message. The system voices the following options:

To Hear the Current Broadcast Message	Press 1
To Re-record the Broadcast Message	Press 2
To Delete the Broadcast Message	Press 3
To Exit	Press #

- To record a broadcast message, **press 2**. Follow the prompts to complete the procedure.

3.3.3 Transferring a Caller to a Mailbox's Voice Mail

Use the following procedure to transfer a caller directly to a mailbox, without having the system attempt to ring the mailbox's associated extension.

- Press the **TRANSFER** key on the telephone.

2. Dial the number for voice mail or press the voice mail hotkey.
3. Dial the **number of the mailbox** to which you want to transfer the call.
4. To divert the call directly to the mailbox's voice mail, press *.
5. Hang up the telephone.

3.3.4 Troubleshooting System Problems

Follow these guidelines to effectively report problems you may encounter:

Gather as much detail concerning the situation as possible:

- Time and date the problem occurred.
- Box and extension number(s) affected.
- Action immediately preceding problem.
- Action taken since problem occurred.

Attempt to duplicate the problem:

- Note the actions taken that apparently invoke the problem.
- Recall any recently made system set up changes that may be contributing to or causing the problem.
- Attempt to duplicate the problem. If you cannot duplicate the problem, it may be have been attributed to user error.